

How to Drive Steel Sheet Piles



*American
Piledriving
Equipment, Inc.*

APE Pile Driving School



What Is a Steel Sheet Pile?



Sheets of Steel plates that interconnect.

Examples





Examples



Example

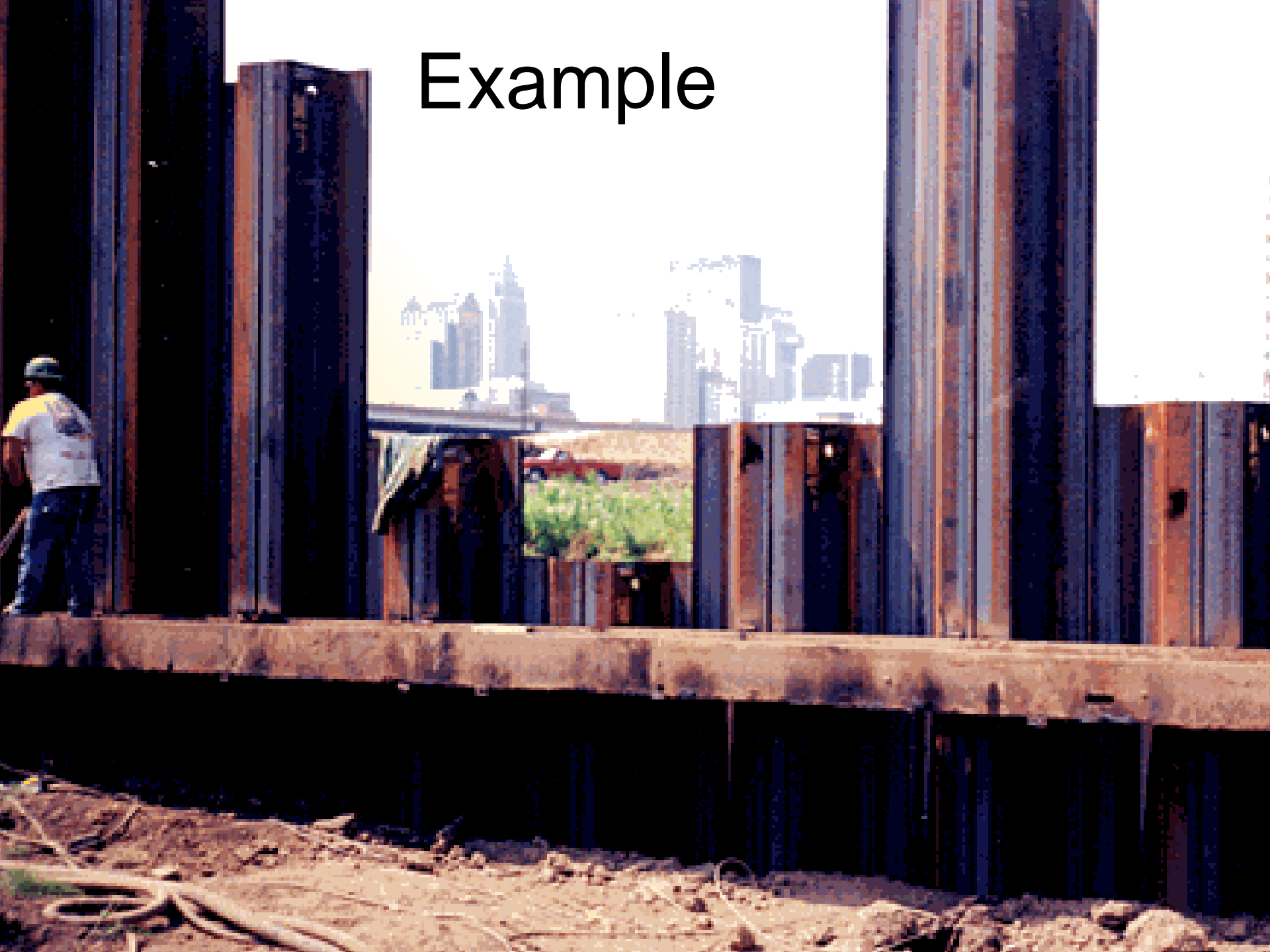

Examples



What Do They Look Like?

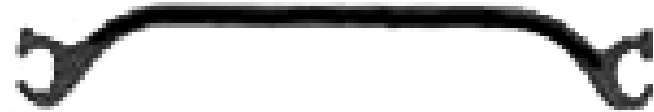
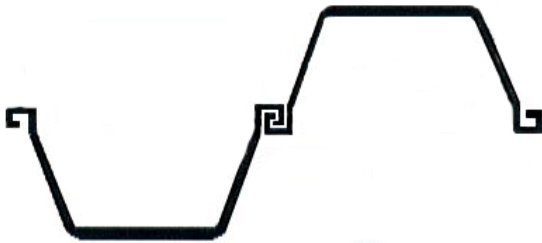
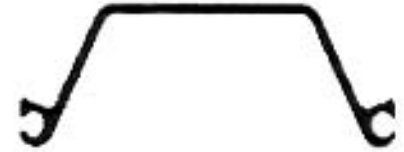
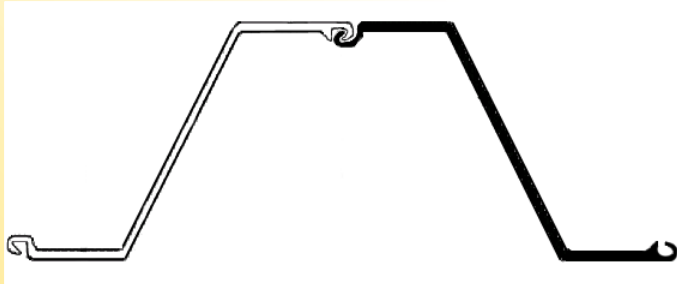

Various Types at a Glance

Z Sections

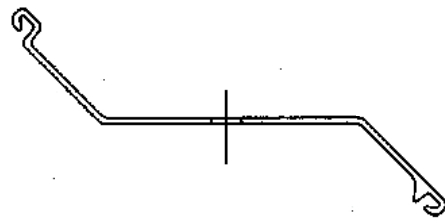
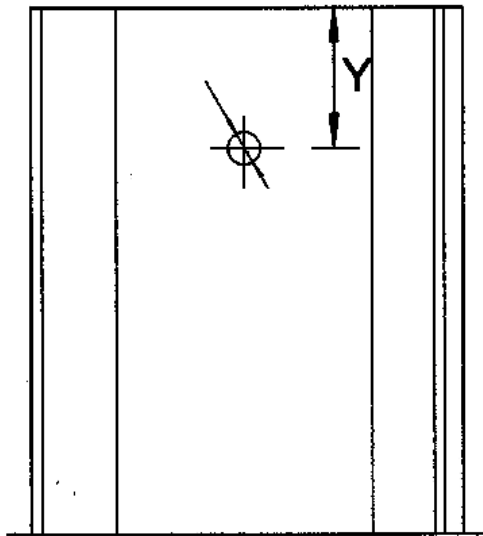

U Sections

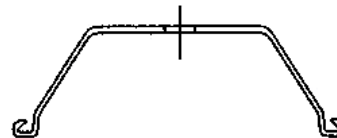
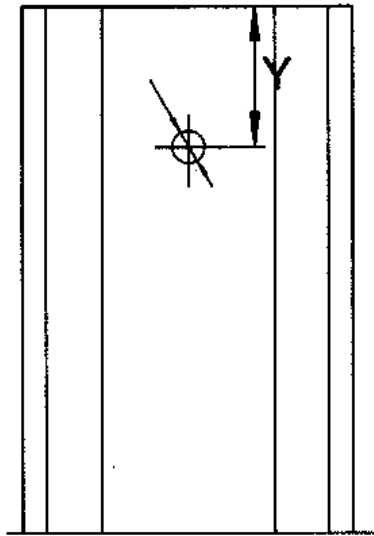

Straight Web Sections

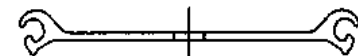
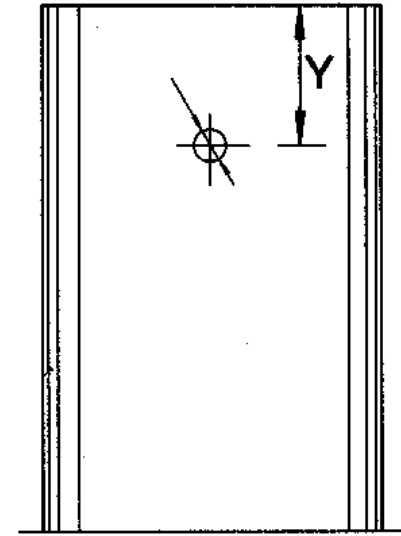

Job Examples



Sheet Pile

Terminology:

Section Data: Name

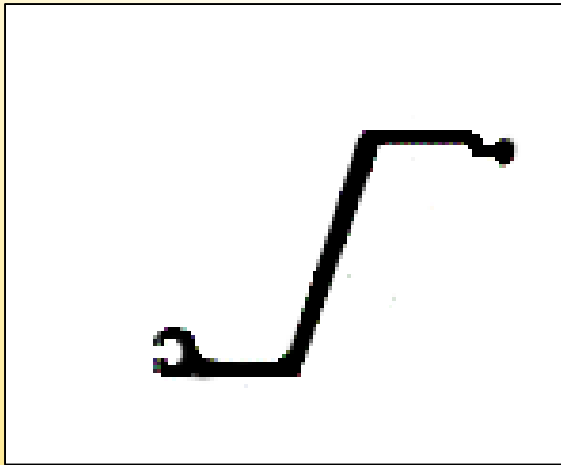

Section Name: Manufacturer's Designation to identify the section. Example: PZ-27

PZ-27 means Z-Shaped with 27 pounds Per square foot.

Job Examples



Sheet Pile

Terminology: *Producer and Country of Origin*

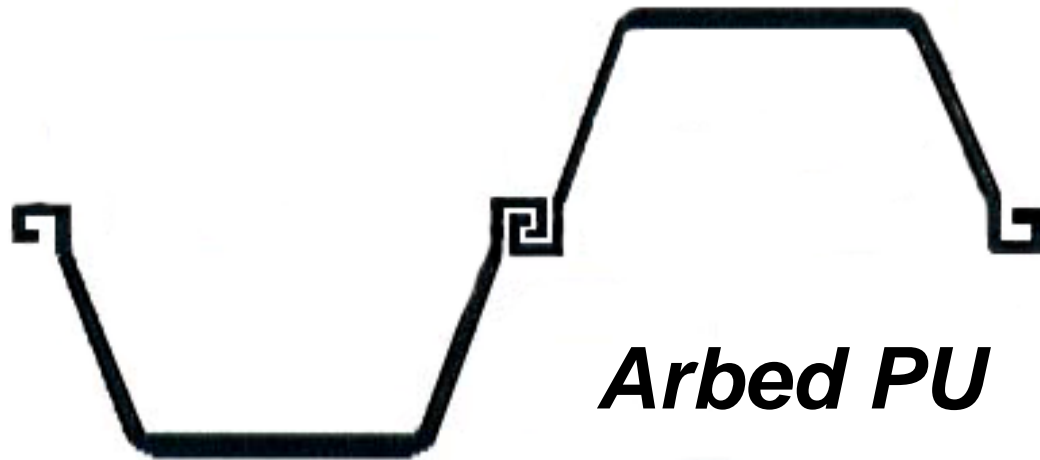

Germany, England, Japan,
USA, Korea, Luxemburg, Etc.

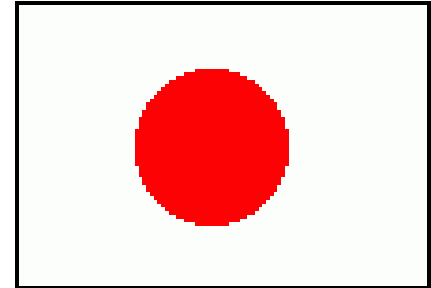

Sheet Pile Terminology:

Shape: 4 Basic Types

1. Z-type (Z)

Arbed PU

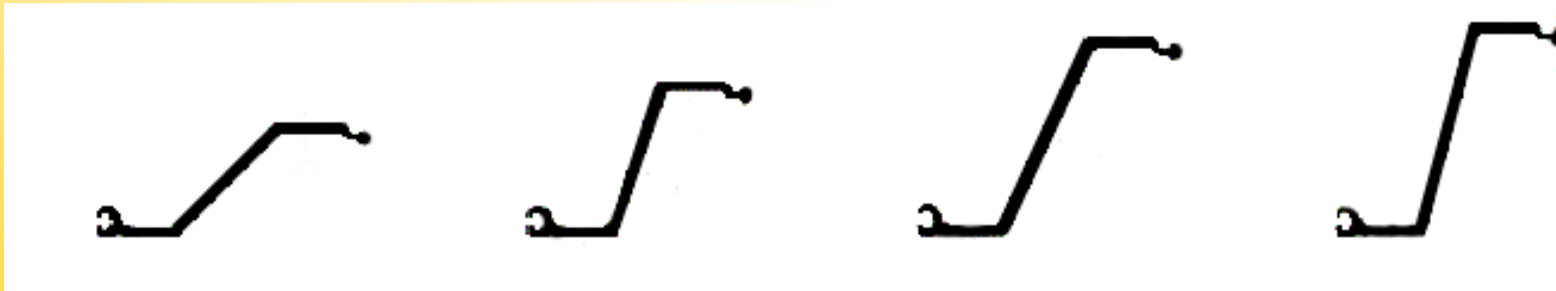
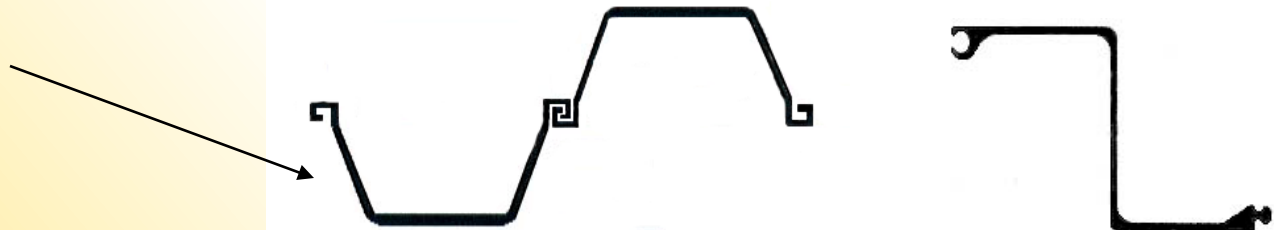

PZ-22

PZ-27

PZ-35

PZ-40

Used for Intermediate to Deep Wall Construction

Sheet Pile Terminology:

Shape: 4 Basic Types

2. U-type (U)



Used For Applications Similar to
Z-Piles

Sheet Pile Terminology:

Shape: 4 Basic Types

3. Flat Sheets (*F*)



Used to form Cellular
Cofferdams



Flat Sheets

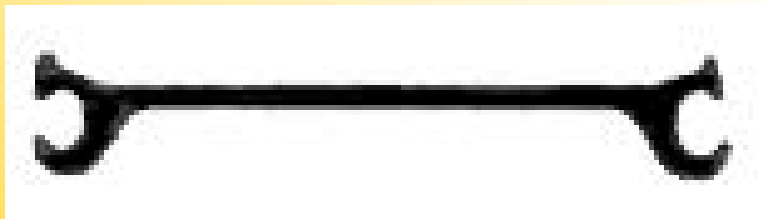



ar c



Examples



Sheet Pile Terminology:

Shape: 4 Basic Types

4. Arch (A)

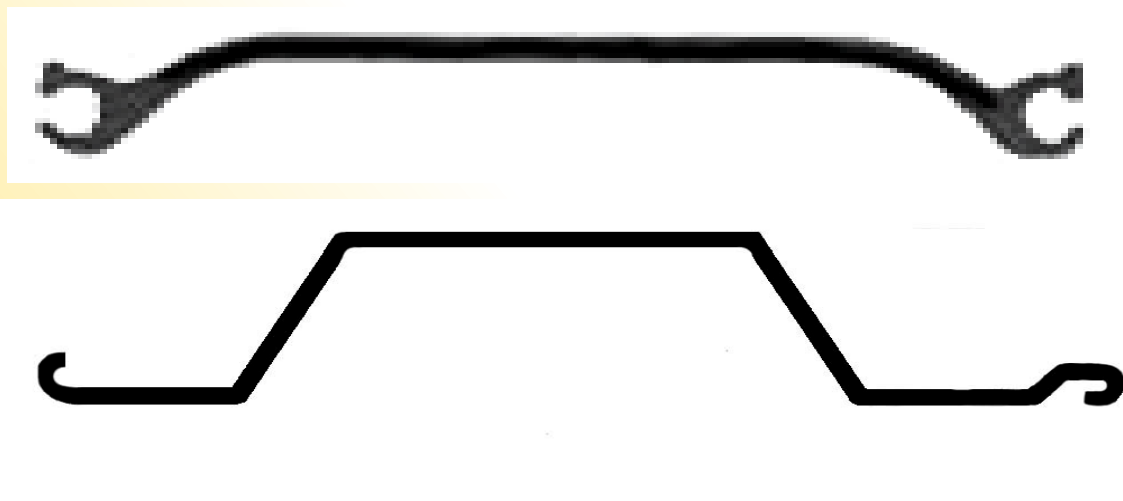

Used For Shallower Wall Construction. Also Comes in Light Weights or Gauges.

Description

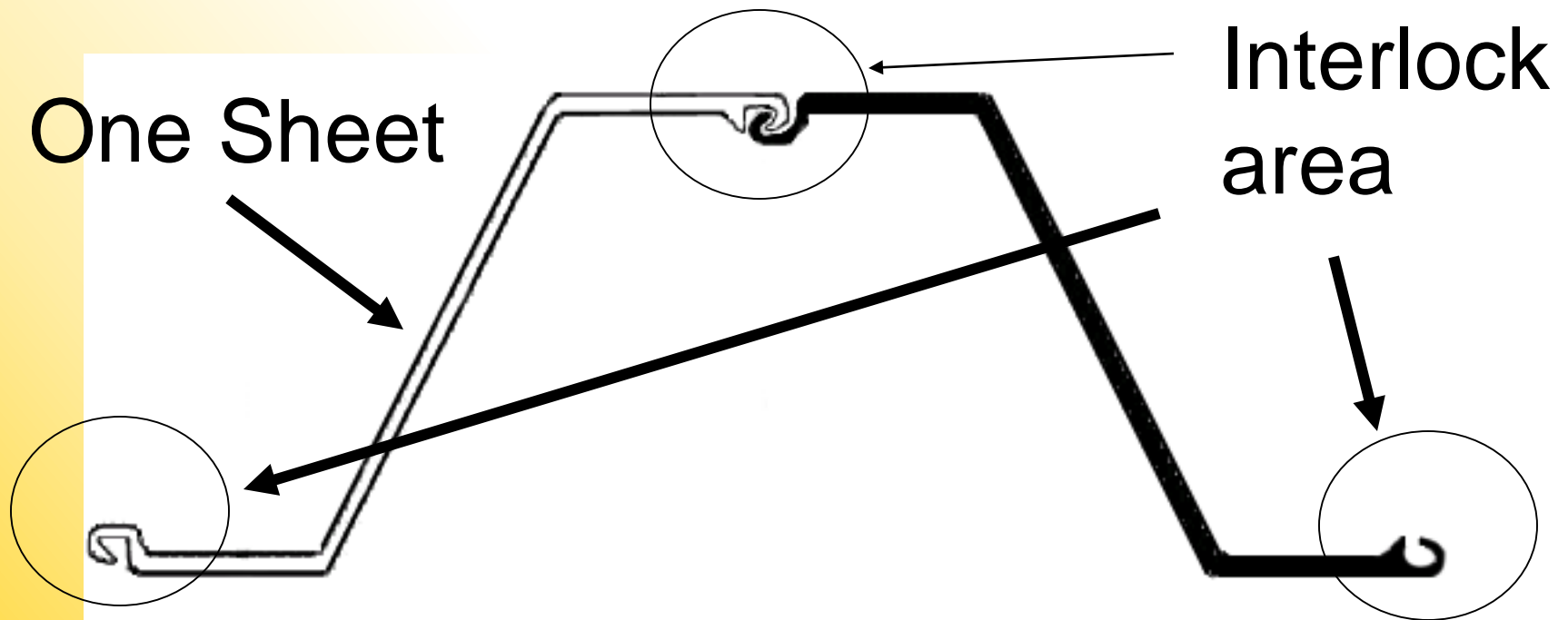

Two Z Shaped Steel Sheet Piles Interlocked together to form a “pair” or “double sheet”.

Types of Steel Sheet Piles: Trench Shoring HOESH

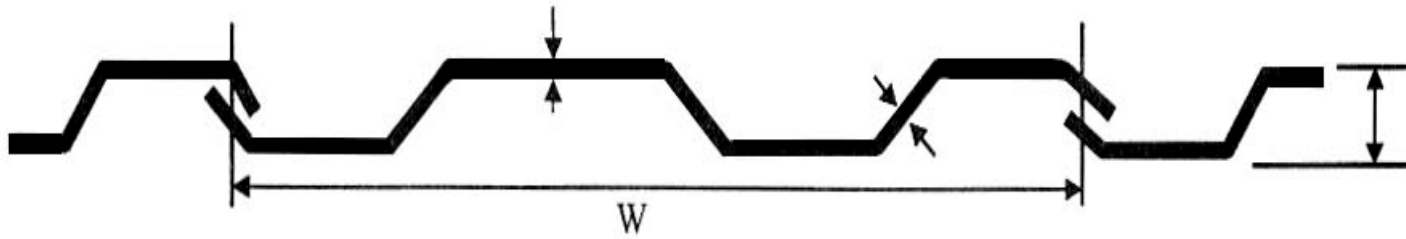

Note: No interlocks

Types of Interlocks

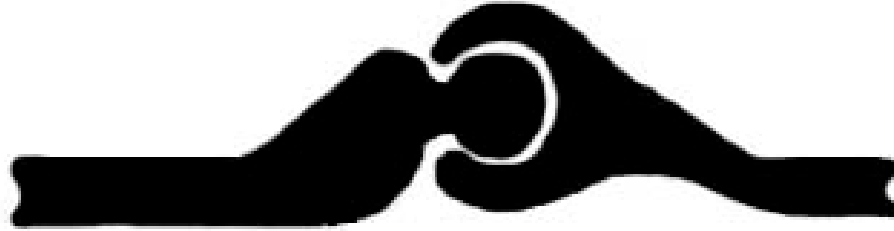

PZ-27

Ball and Socket Type

Positive Points:

- *Easy to thread. Hangs up less.*
- *Pile Crews Desire This Type of Interlock*
- *Super Rugged Interlock*
- *Great for Repeated Use.*
- *Easy to Drive because Interlock displaces less soil*

Types of Interlocks

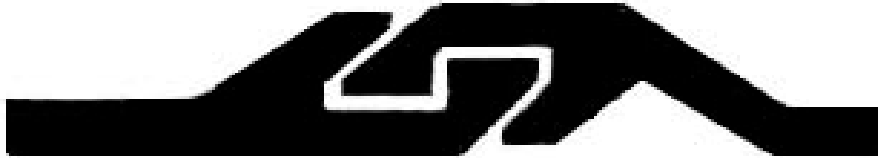

Double Jaw

Positive Points:

- *Proven Track Record*
- *Tight interlocks-Less Seepage*
- *Strong for repeated use.*
- *Good in Hard Driving Situations*
- *Small profile Interlocks*



Single Jaw

• *Negative:*

- *Less Swing*
- *Hangs up more*
- *Holds up good but not as good as the ball and socket type interlock.*

Types of Interlocks

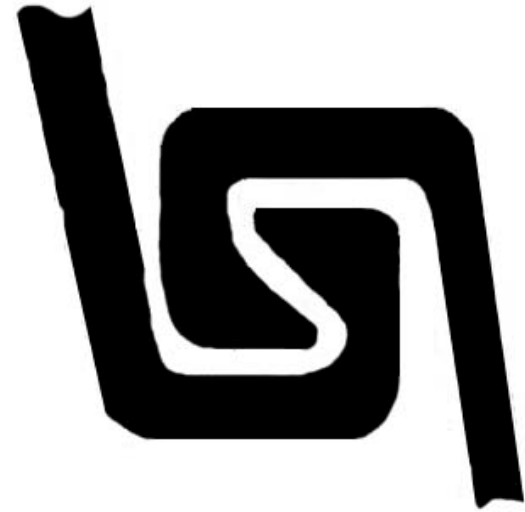

Double Hook

Positive Points: *Proven Track Record*

Negative: *Limited Swing*

Types of Interlocks



Cold Rolled Hook and Grip

- Avoid if hard driving
- Avoid if sealing out water

Types of Interlocks

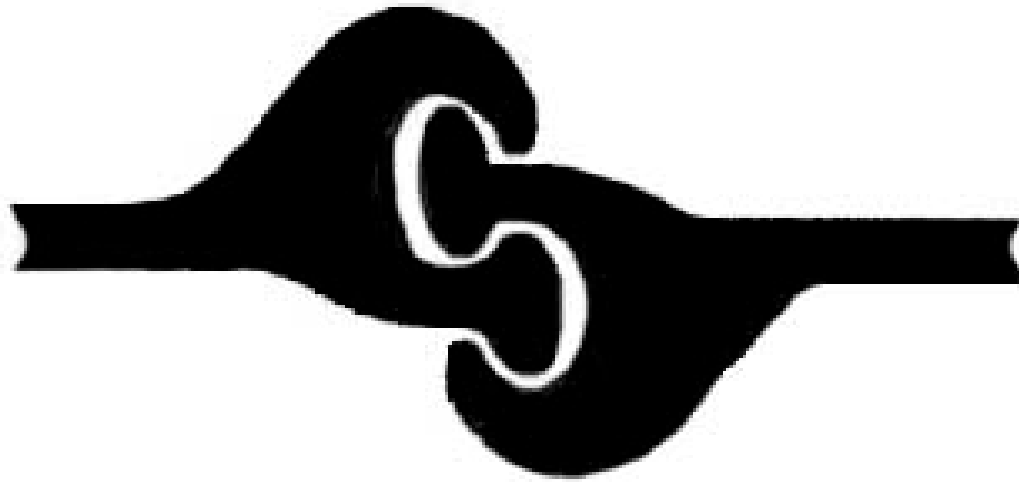

Thumb and Finger- Three Point Contact

Thumb and Finger Interlock is Used on Flat Sheet Piles. Interlock is rated by Tension Strength. Used for Cofferdams.

Types of Interlocks

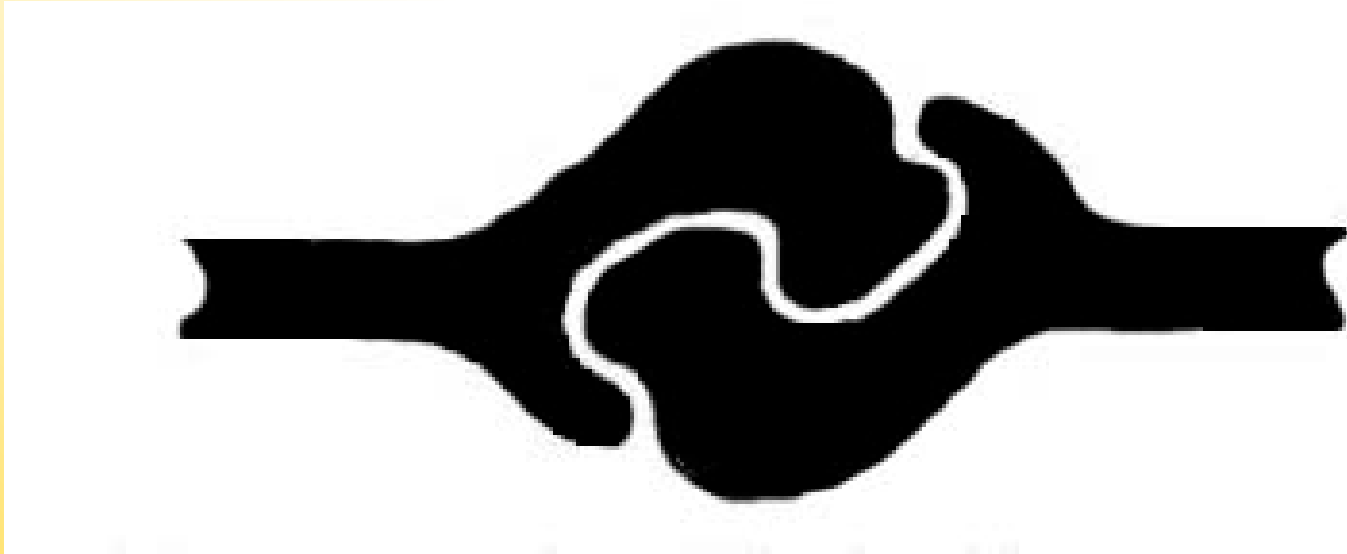

Thumb and Finger- One Point Contact

Reading Sheet Pile Dimensions: *Section Area*

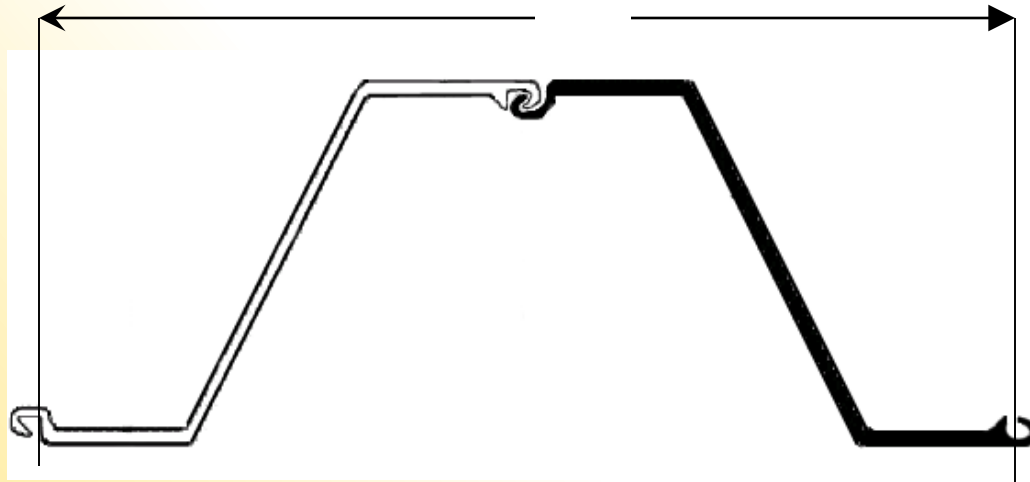

Cross-sectional area is listed as square inches per foot of wall.

Areas shown for flat piling are based on the single section only.

Reading Sheet Pile Dimensions: *Nominal Width*

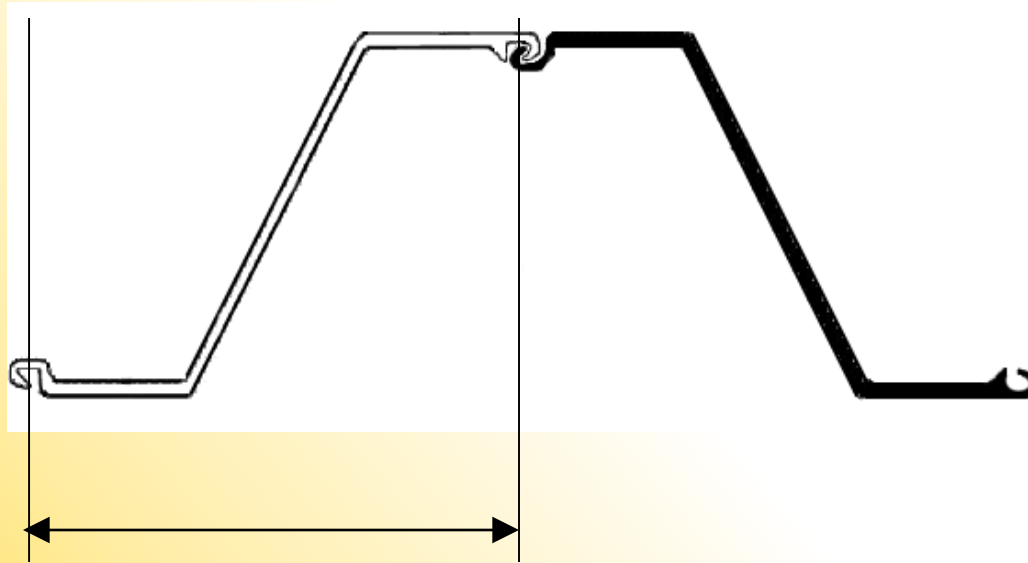

Centerline from Interlock to Interlock



Reading Sheet Pile Dimensions: *Weight*

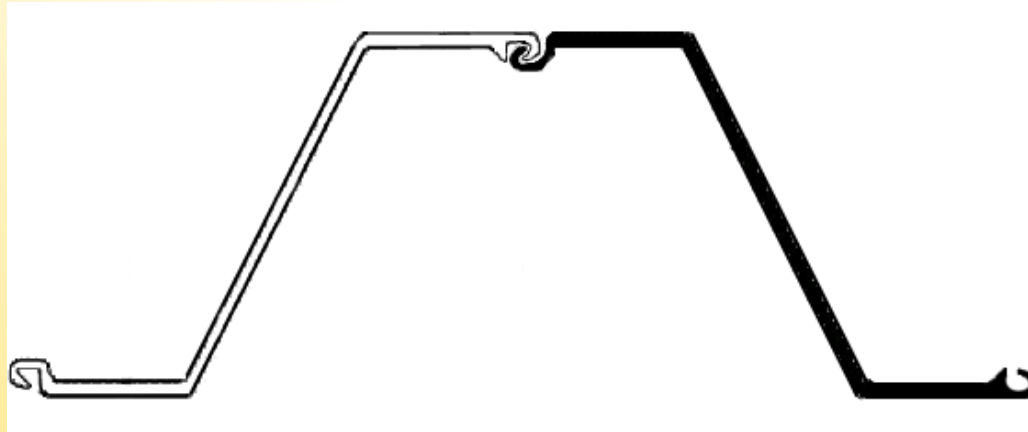

Weight of Square Foot of Wall

Reading Sheet Pile Dimensions: *Wall Depth*

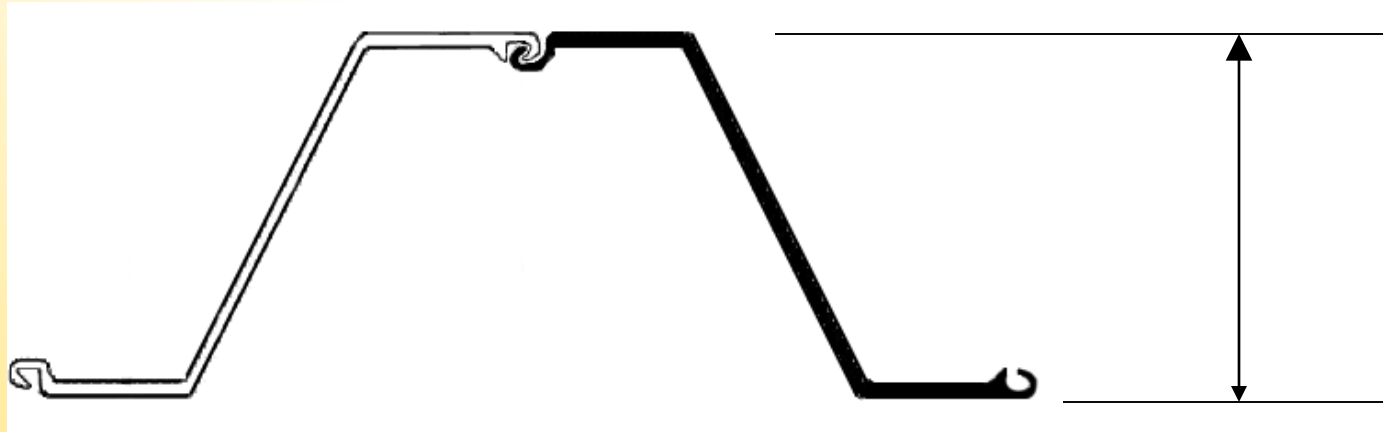

Distance between outboard and
inboard Faces

Reading Sheet Pile Dimensions: *Wall Web and Flange*

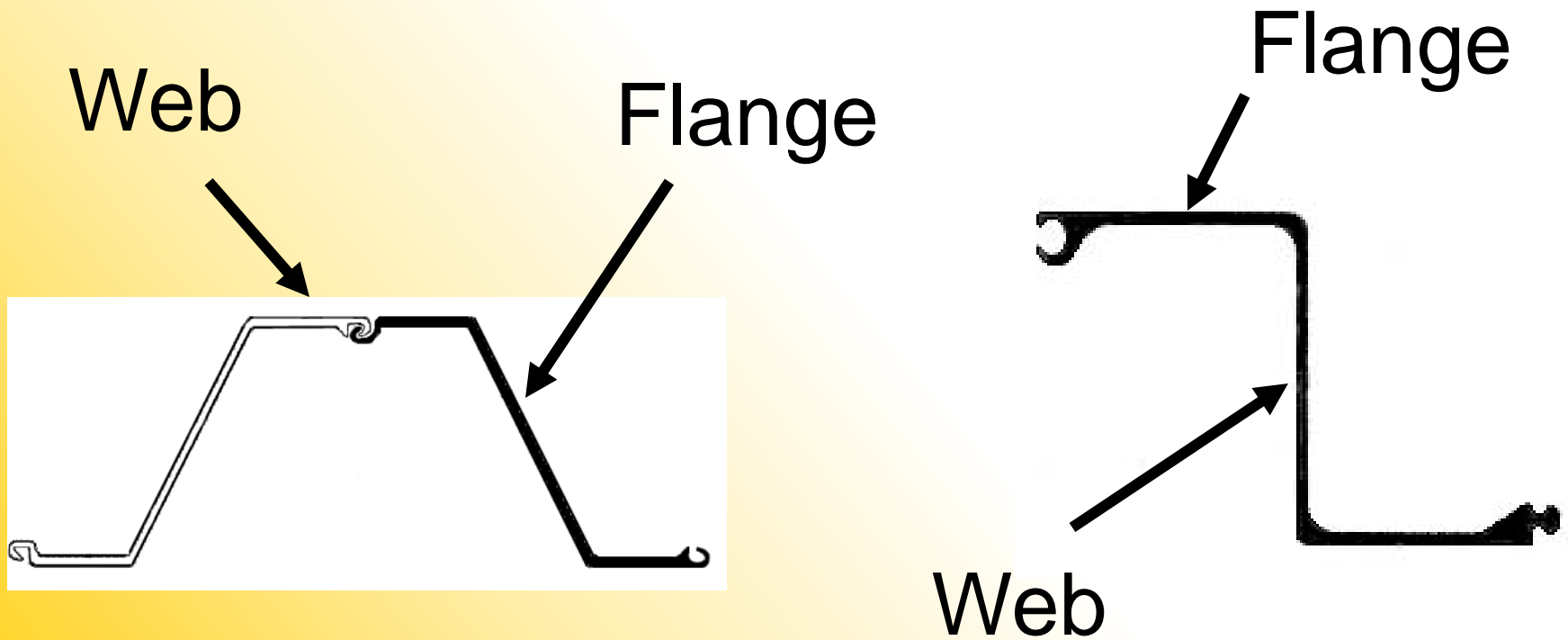

Reading Sheet Pile Dimensions: *Moment of Inertia*

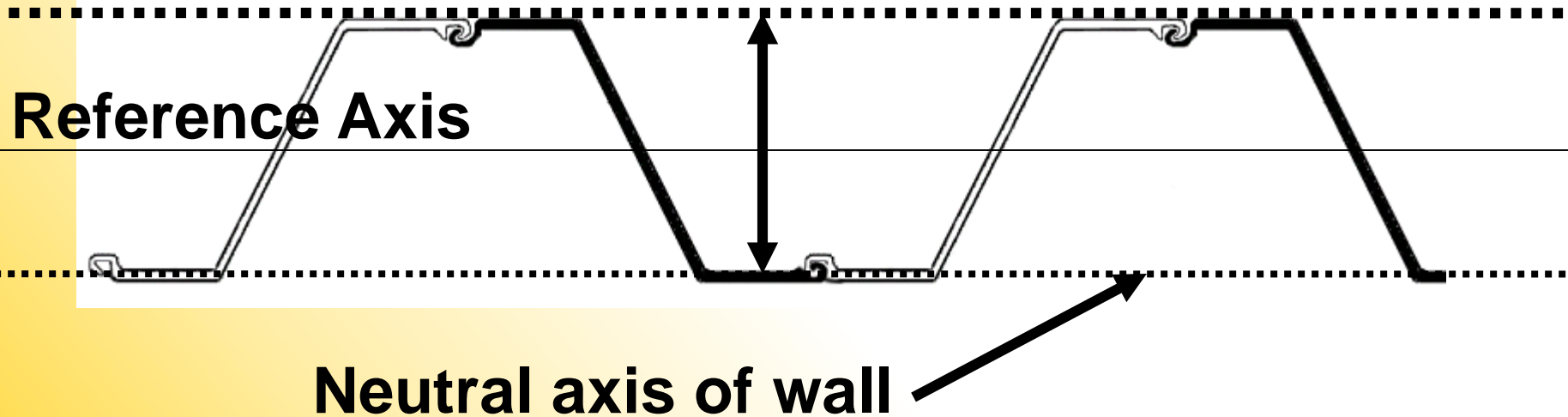

Product of cross-sectional area and squared distance from a reference axis



Reading Sheet Pile Dimensions: *Section Modulus*

What to Consider Beyond
Section Modulus and Moment of
Inertia.

Choosing The Right Sheet Pile
for The Job Based on Driving
Conditions and Dewatering
Requirements.

Understanding the Difference Between Hot Rolled and Cold Formed.

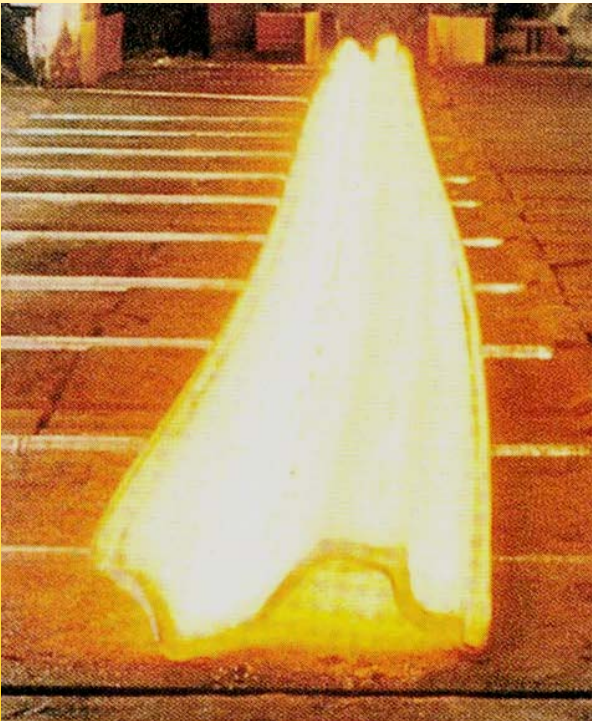

Sheet Pile Terminology:

Hot Rolled (HR)

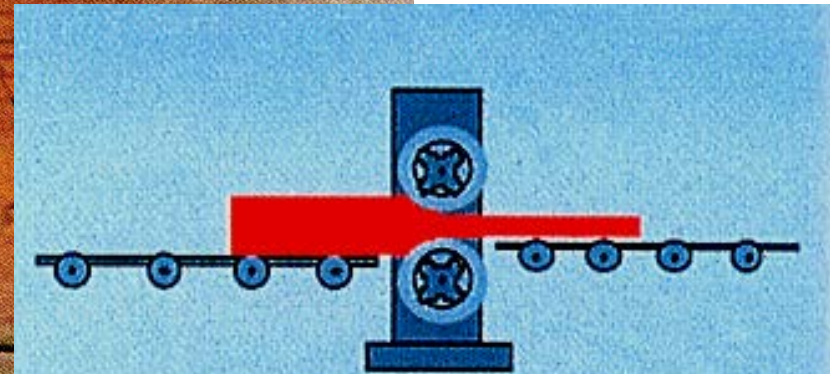
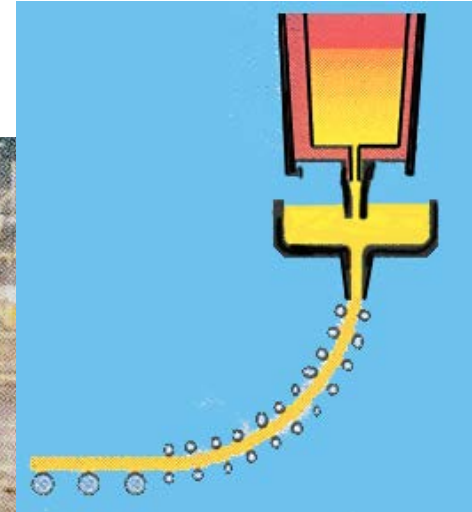

Rolling mill



Hot Rolled Steel Sheets

Good Points:



- Proven track record since early 1900's
- Tight interlock for good water seal
- Proven procedures to reduce seepage based on 100 years of data
- Less interlock slop reduces tendency to lean and reduces template criteria
- Strong interlock for hard driving
- Can be made with thick (up to $\frac{3}{4}$ inch) wall for super hard driving
- Web layout superior to cold formed (for hammer energy transfer)
- More elastic at angle area (cold forming process reduces elasticity)
- Excellent for reuse due to strong interlocks
- Available for rent and rental/purchase



Hot Rolled Steel Sheets



Bad Points:

- Costs more than cold formed
- Restricted lengths 25 feet to 60'
- Lengths restricted to 5' intervals
- Special lengths are special order
- May weigh more per foot of wall
- May not be necessary in super soft soils

Cold Formed Steel Sheet Piles Are:

**Cold Formed From Steel
Sheet Rolls Called Scalp or
Coils**

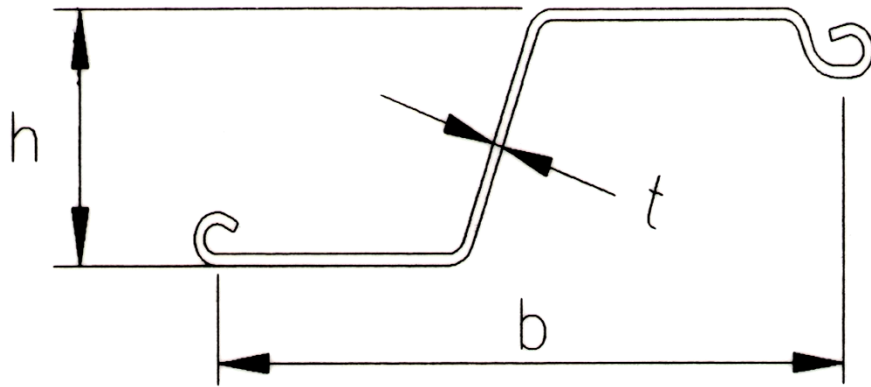

Cold Formed Steel Sheets

Good Points:

- Much Cheaper to make than hot rolled
- Can get cut to any length and quantity
- Fast delivery and production
- 15 to 20 different shapes & thicknesses
- Good for soft driving but requires careful alignment
- Greater swing than hot rolled allows greater curves

Cold Formed Steel Sheets

Bad Points:

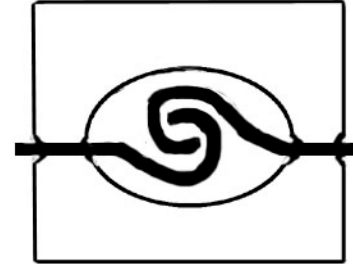

- Weak interlocks
- Cold formed sheet interlocks much larger than hot- harder to clamp*
- Sloppy interlocks get jammed easy from soil entering
- Seepage problems
- Brittle at bent areas due to dynamic loading when cold formed
- Interlocks fail in hard soils or when striking obstacles
- Web is longer. Vibratory hammers will rip out tops
- Not good for jobs where sheets must be reused several times
- Not available for rent because interlock failures
- Requires more attention when driving

Jaws on Cold Formed Interlocks

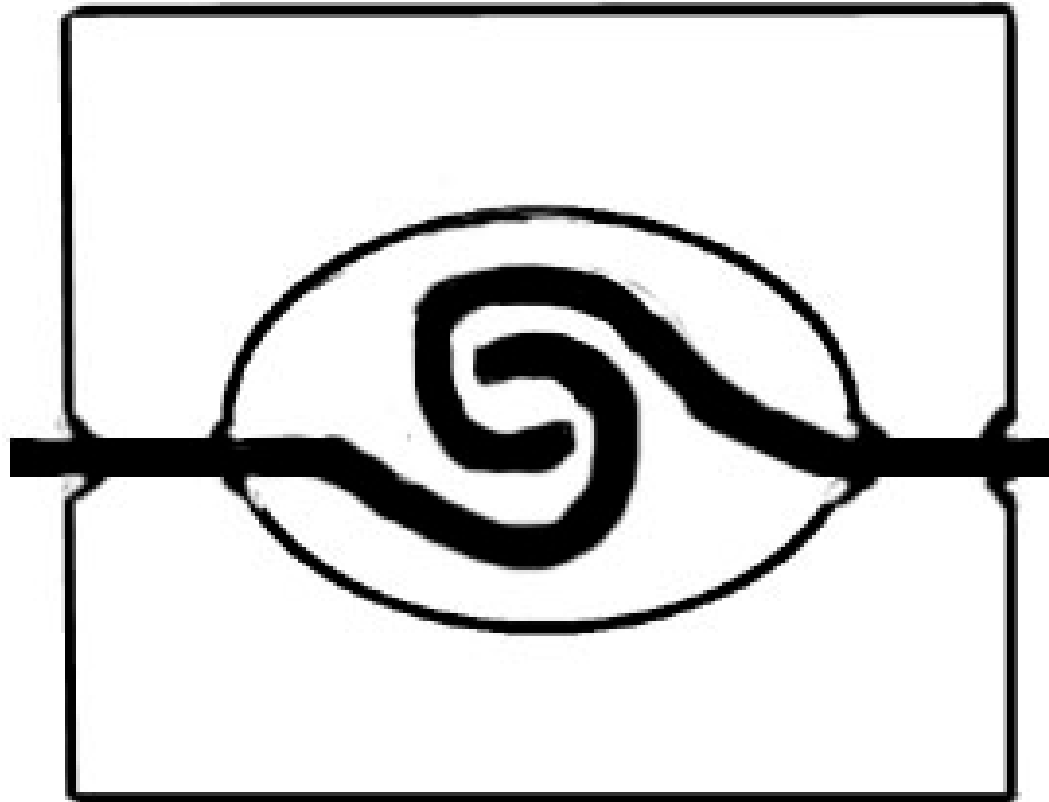

Interlock Jamming

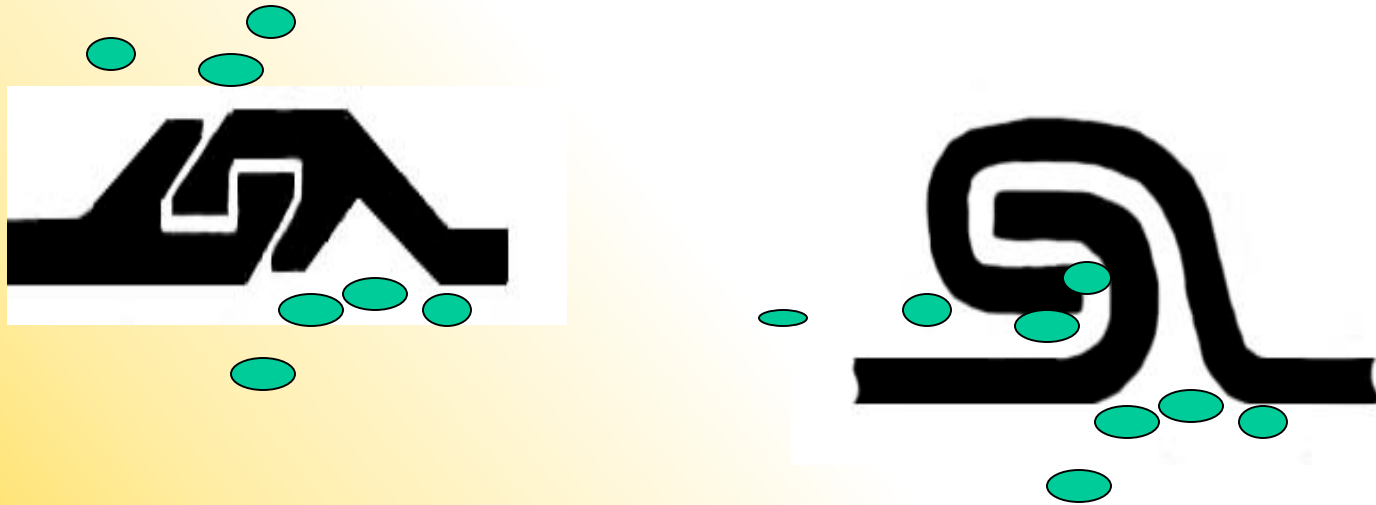

Hot rolled sheets have tighter tolerances that keep larger particles out. Large particles cause hitch hiking of the sheets. Hitch hiking

Dynamic Loading

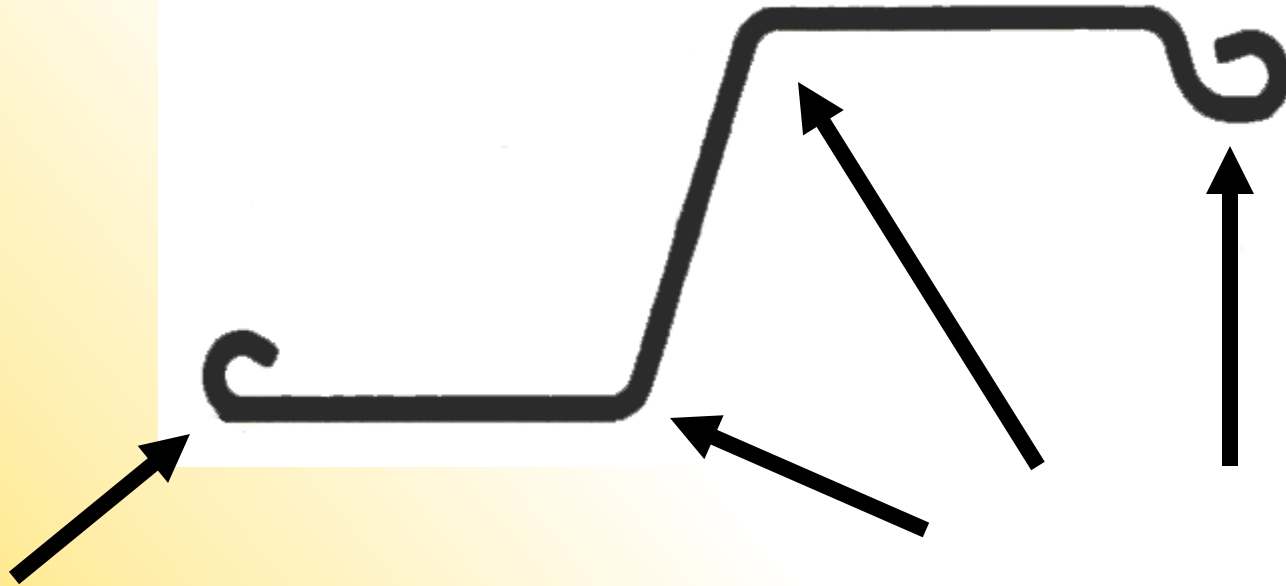

Bending during cold forming loads areas.

Driving Methods- Easy Driving-pitch and Drive

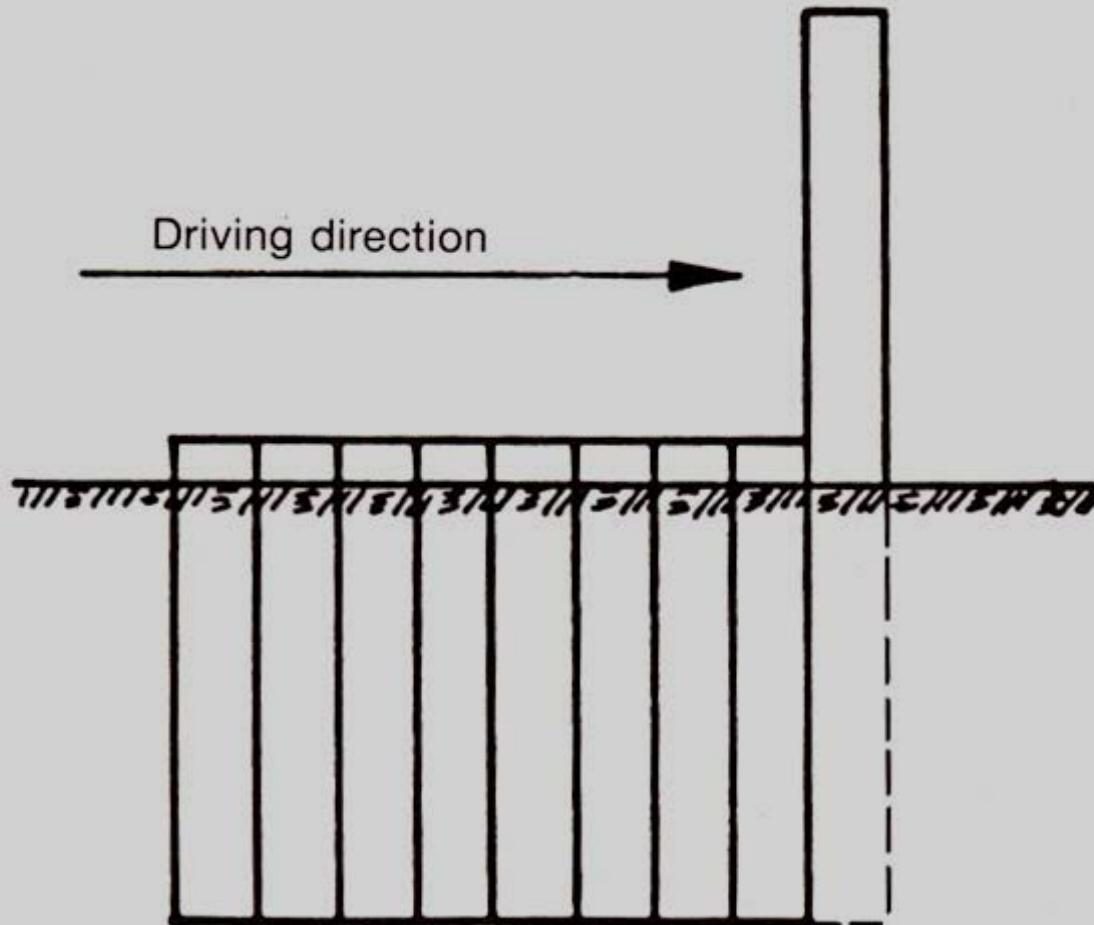

- *Soft Driving*
- *No obstacles*
- *Short Piles*
- *Smart crew*
- *Good sheets*
- *Light Vibro*

Examples- Soft Soils, Short Sheets



Pitch and drive

Driving Methods

Use at Least a Four Foot Level

Use a String Bob

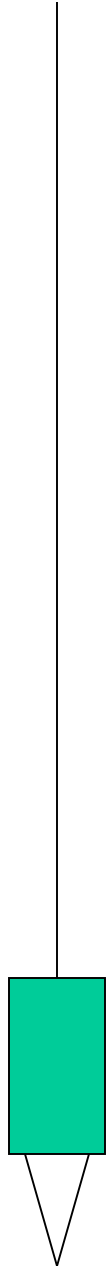
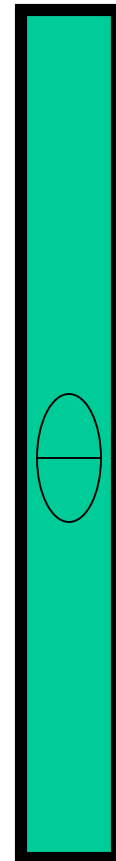
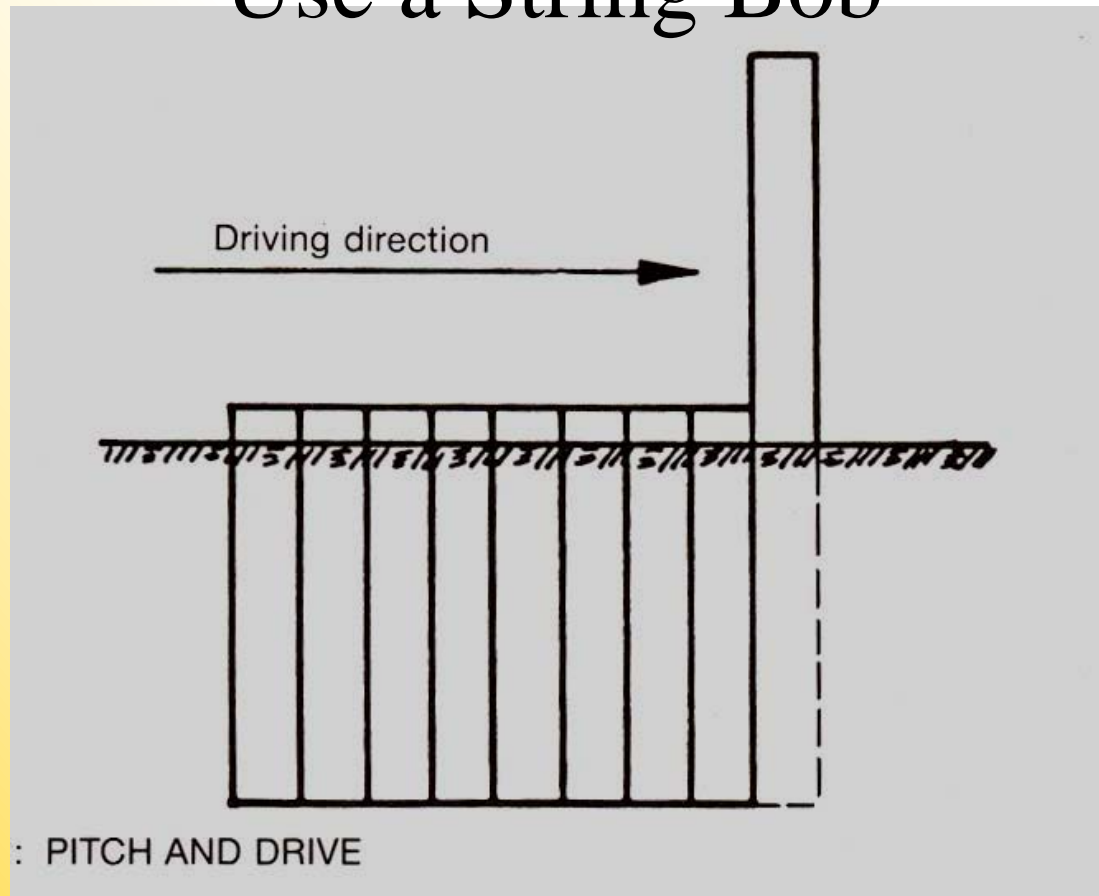

Driving Methods-other than soft

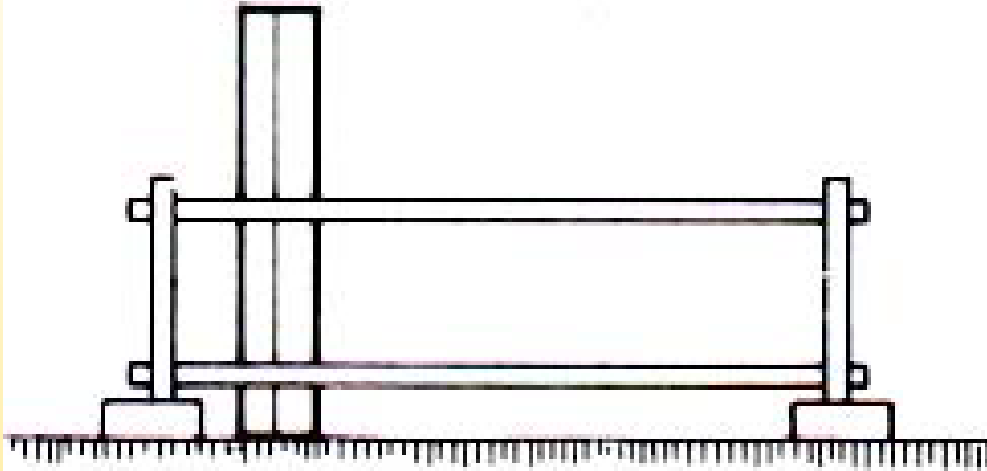

1

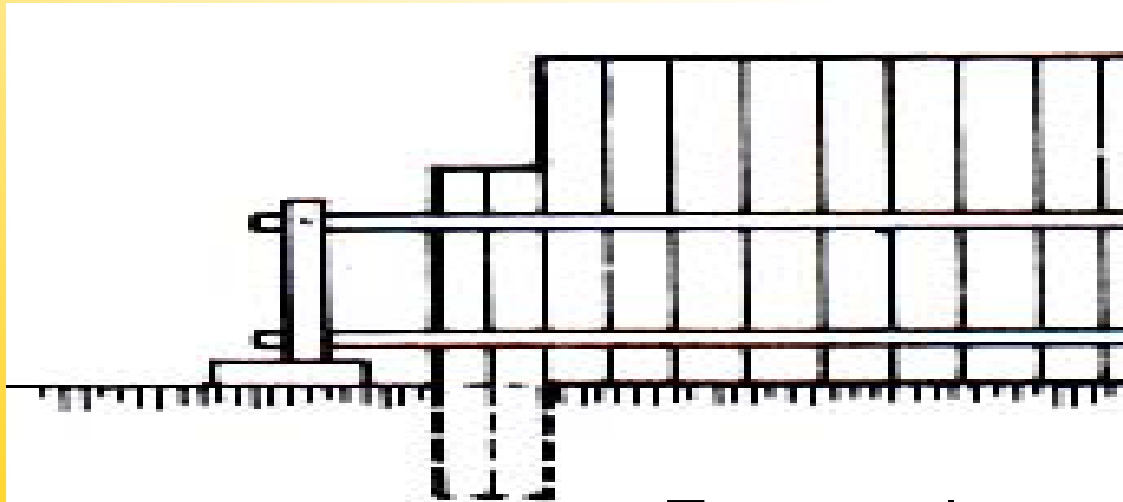

2

Two templates or more. Upper and Lower.

Example of Double Templates



Upper template should be substantial fraction of the pile length.

Driving Methods Gaining or Loosing

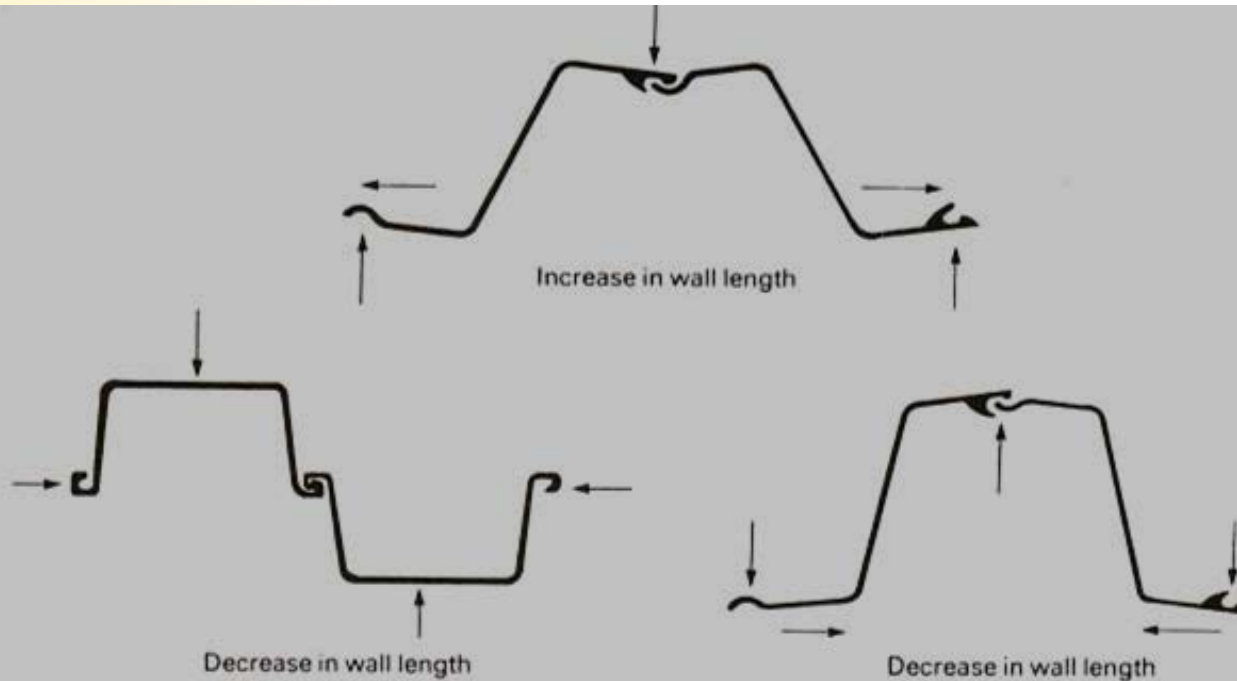
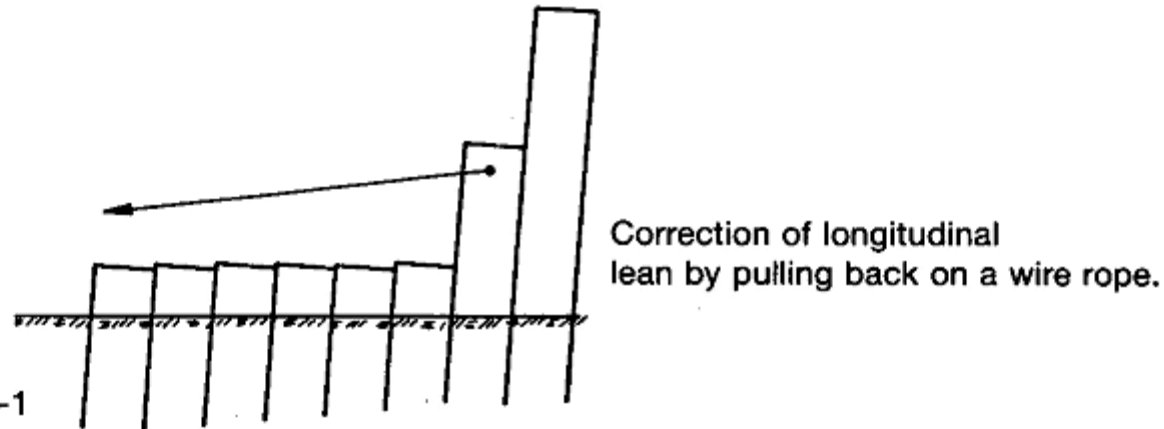

Figure 9.3

Driving Methods-
Leaning
Stop!
Take Corrective Action.



Methods-leaning Corrections



In conjunction with the above method, the hammer can be placed off centre of the pair of piles towards the last driven piles.

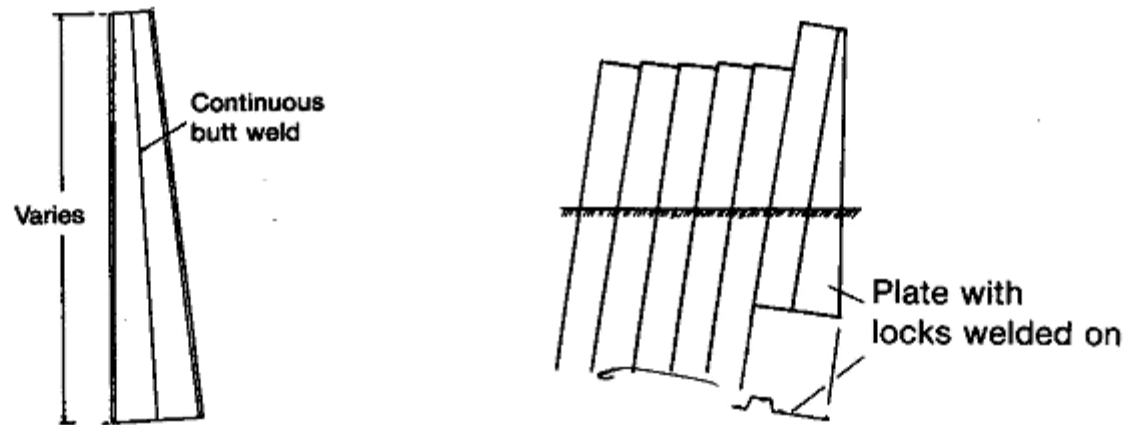

When, in spite of all precautions, a lean cannot be eliminated, taper piles must be employed to correct the error.

Impact Hammers

Things to consider:

- *Heavy ram, shorter stroke*
- *Ram weight should be 1.5 to 2 times the combined pile and cap weight*
- *Diesel hammer may be best choice*
- *Leader mounted*
- *Good drive cap to pile fit*
- *Drive in shorter steps*

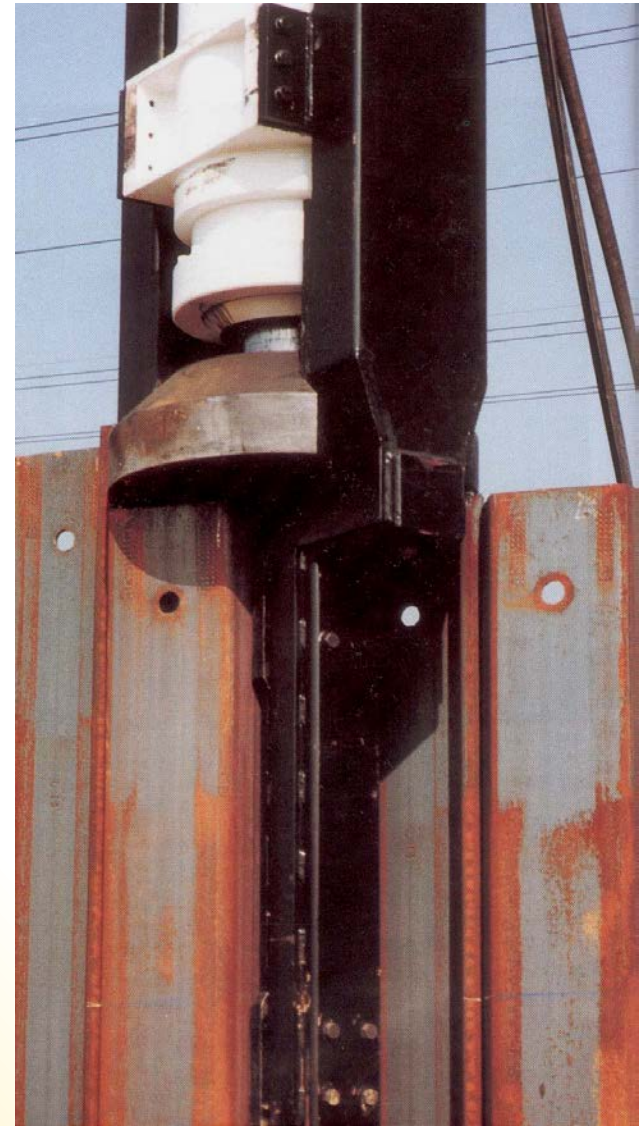

Impact Hammers-drive Caps

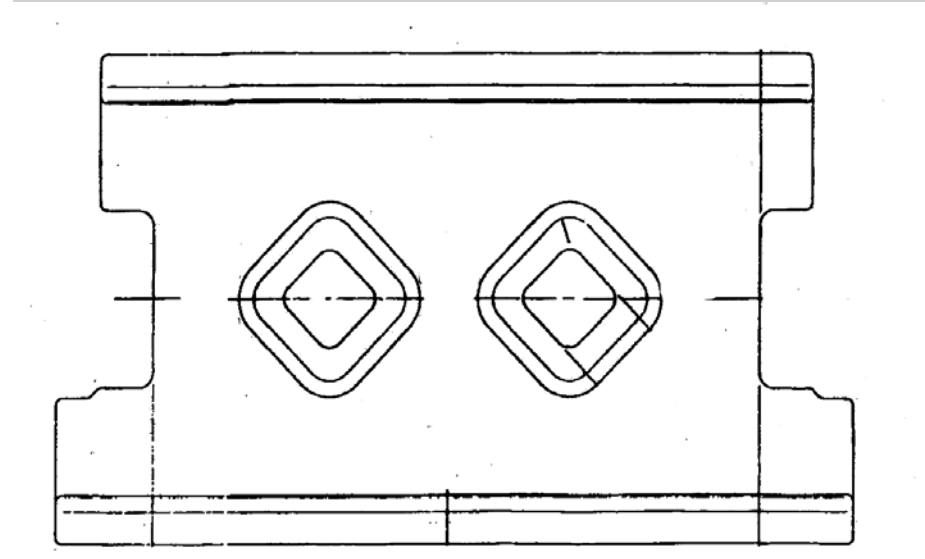
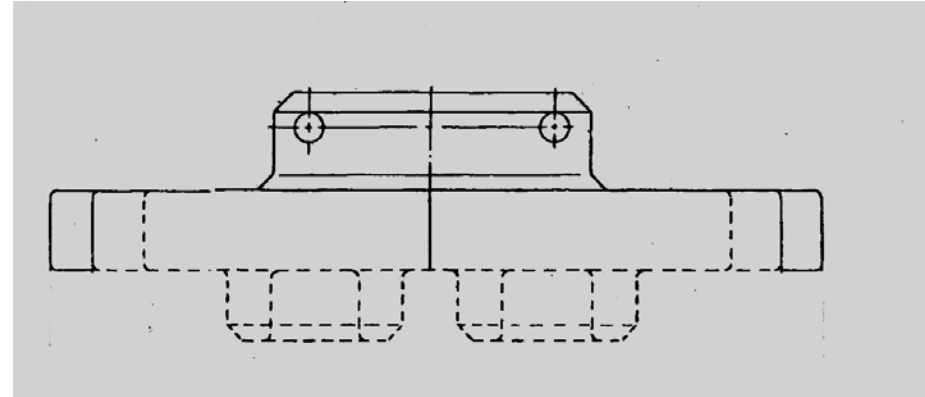
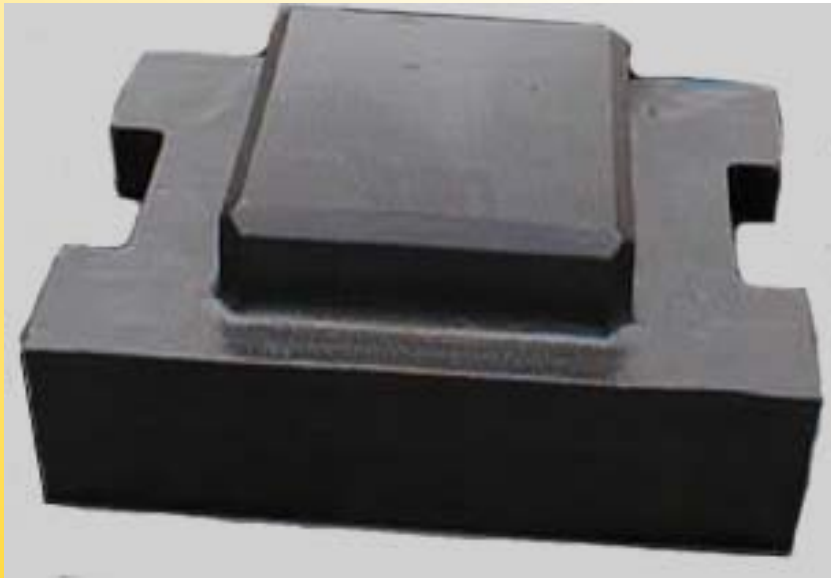



Diesel Hammer



Understanding Vibros

Suppressor

Gearbox

Clamp Device

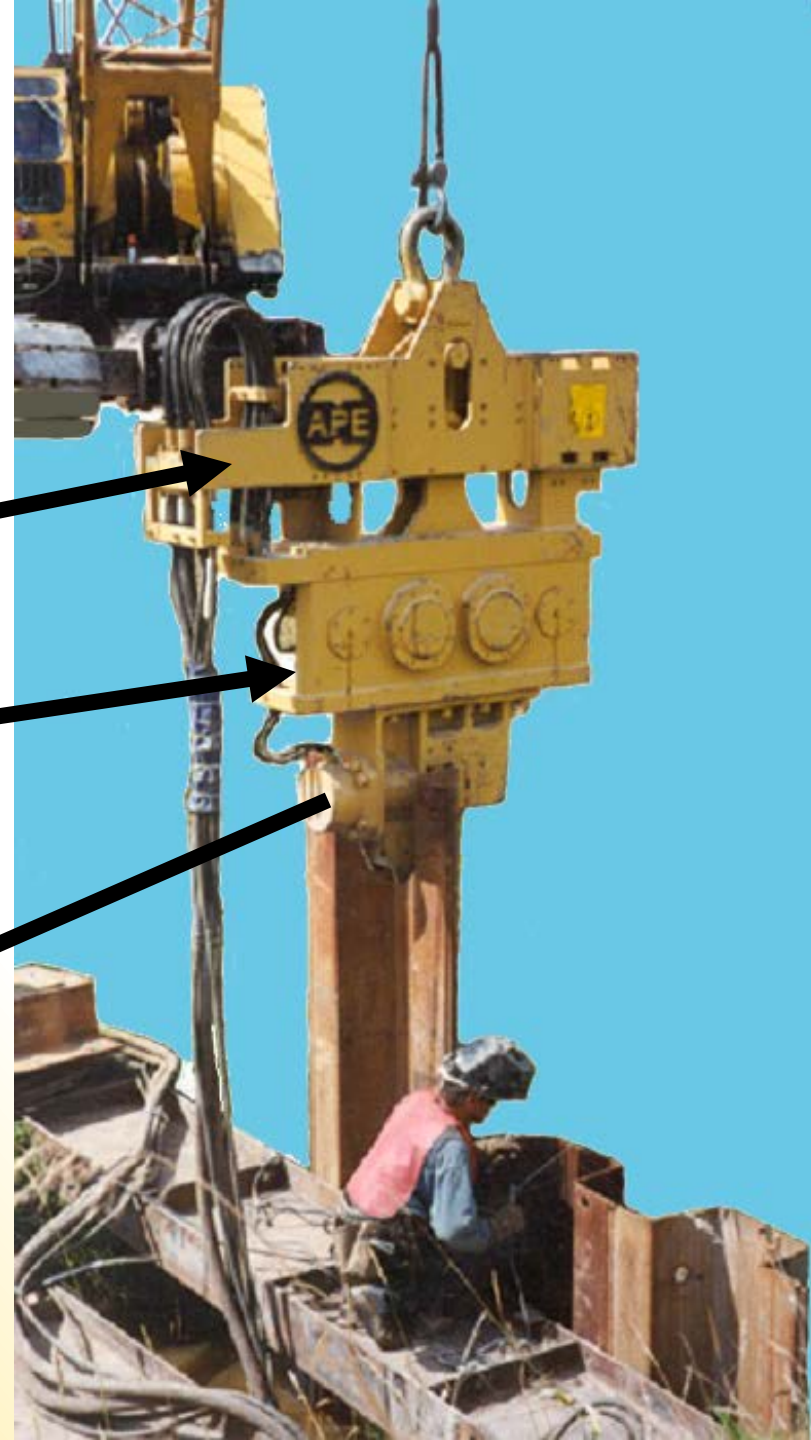

Vibro Suppressor- rubber Springs

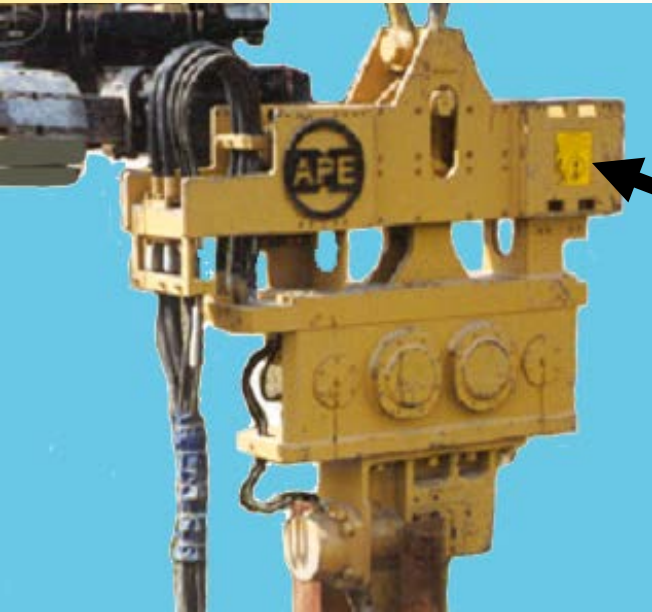

Isolates vibro action from crane line.

Vibro of Rotating Eccentrics

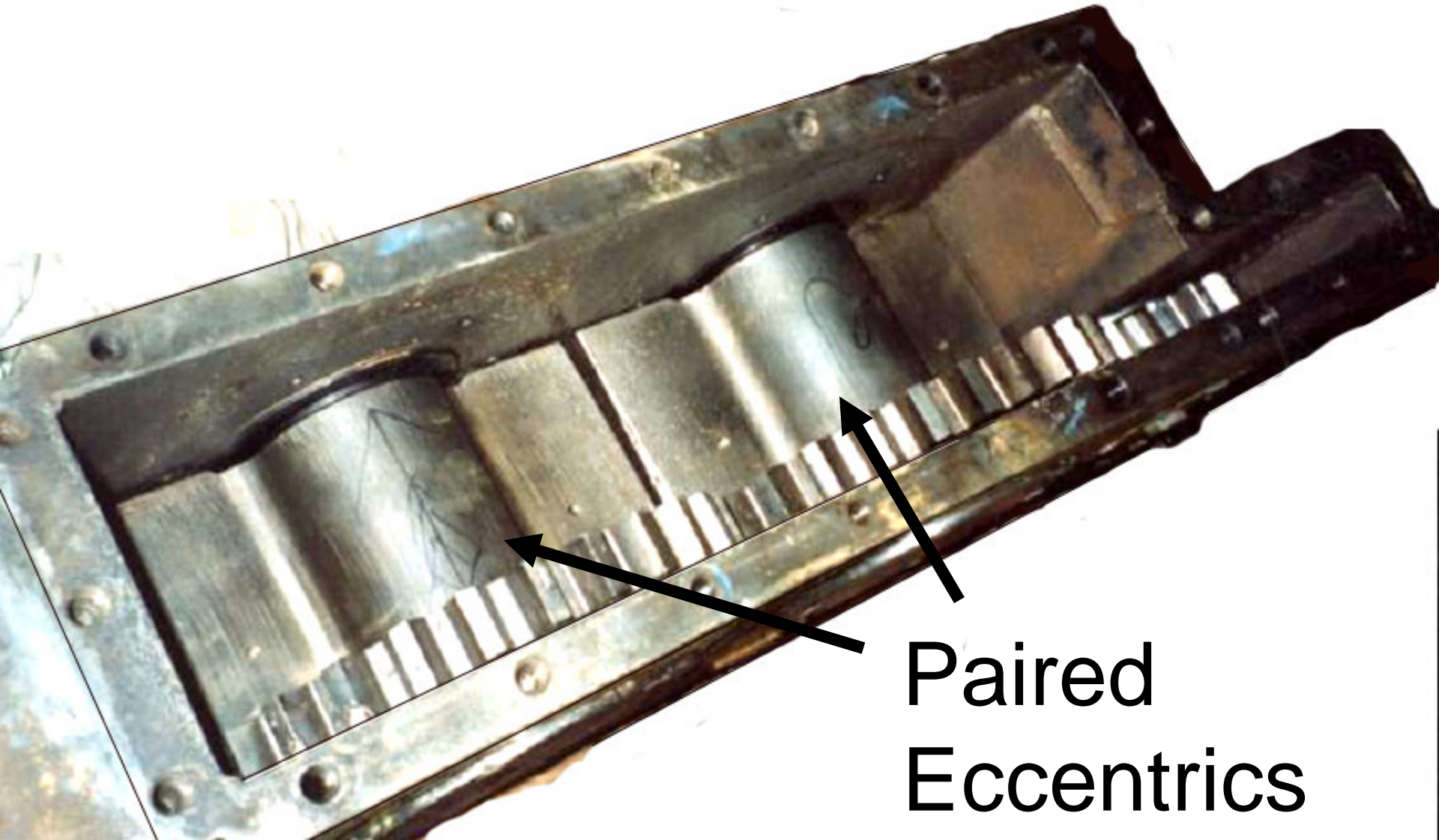

Paired
Eccentrics

Eccentric

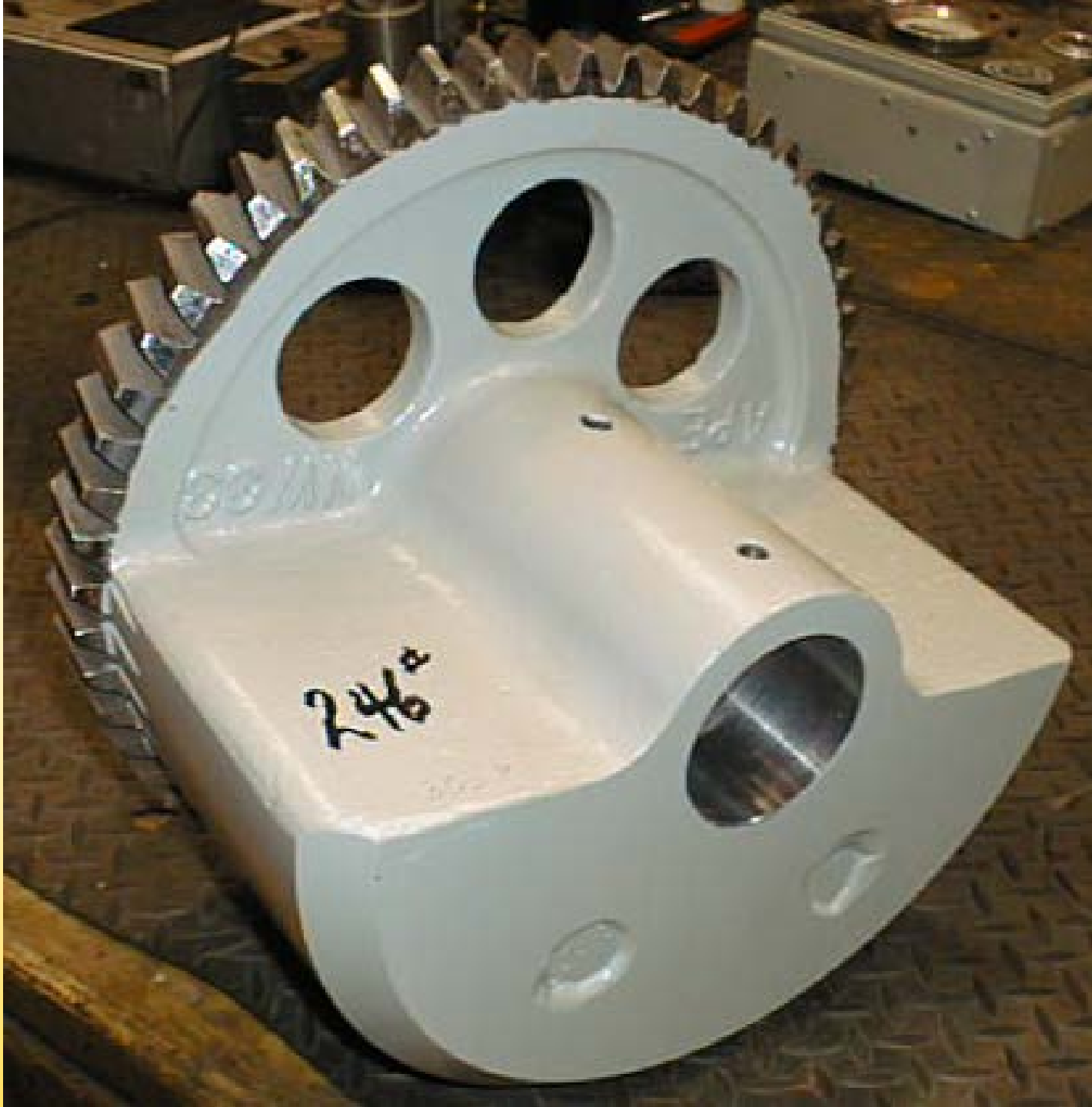

Four Strokes of the Eccentric

1 work



Forces the vibro and the casing downward

2



Nothing happens. Each eccentric cancels other out.

3 work



Both eccentrics for vibro and casing upward

4



Nothing happens. Each eccentric cancels other out.

Vibro-Driver/Extractors

Eccentric moment

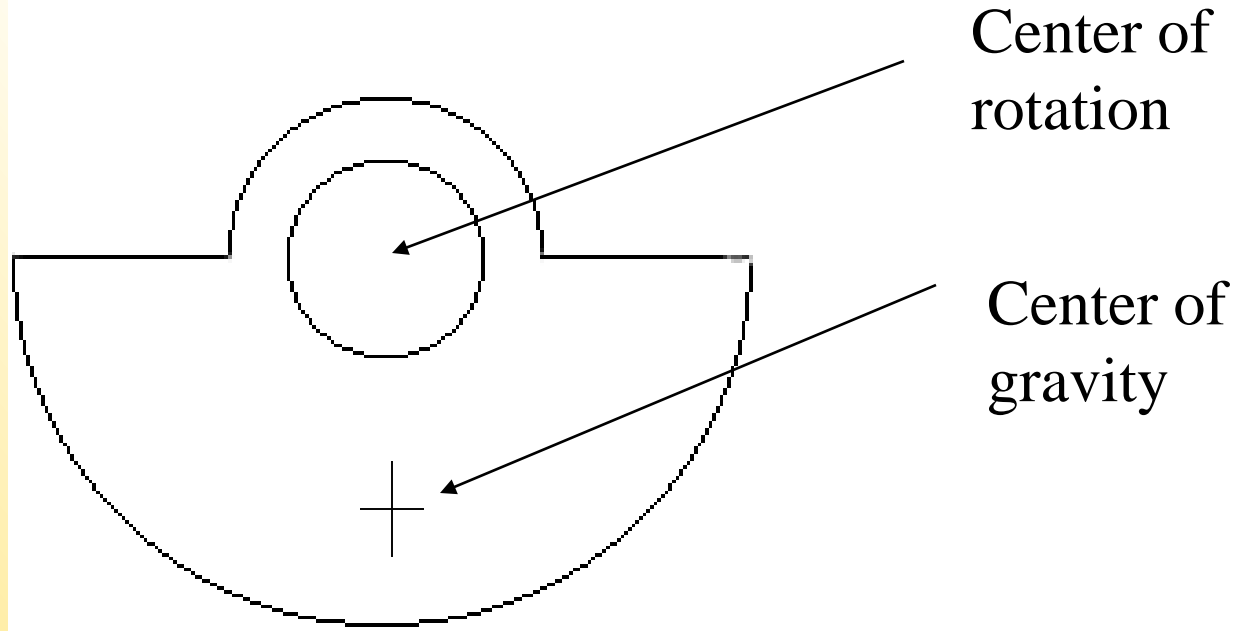

Eccentric moment = distance between the center of rotation and the center of gravity \times the total mass of the eccentric.

Example of calculating eccentric moment of one eccentric:

Equation:

Distance between

Center of Rotation

and

Center of Gravity

Multiplied by

The Mass

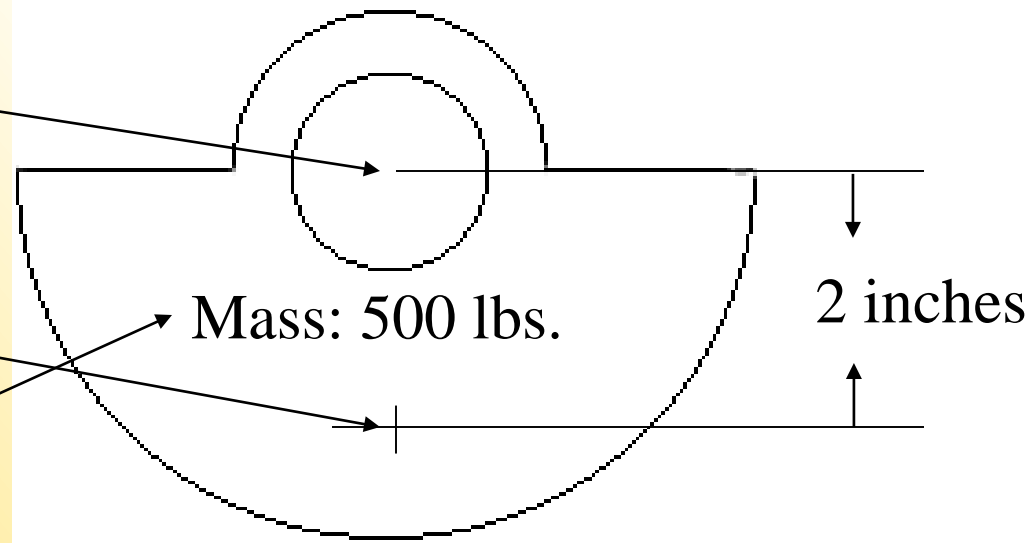

2 times 500 equals: 1,000 inch pounds

Eccentric moment of a vibro is measurement of all eccentrics combined.

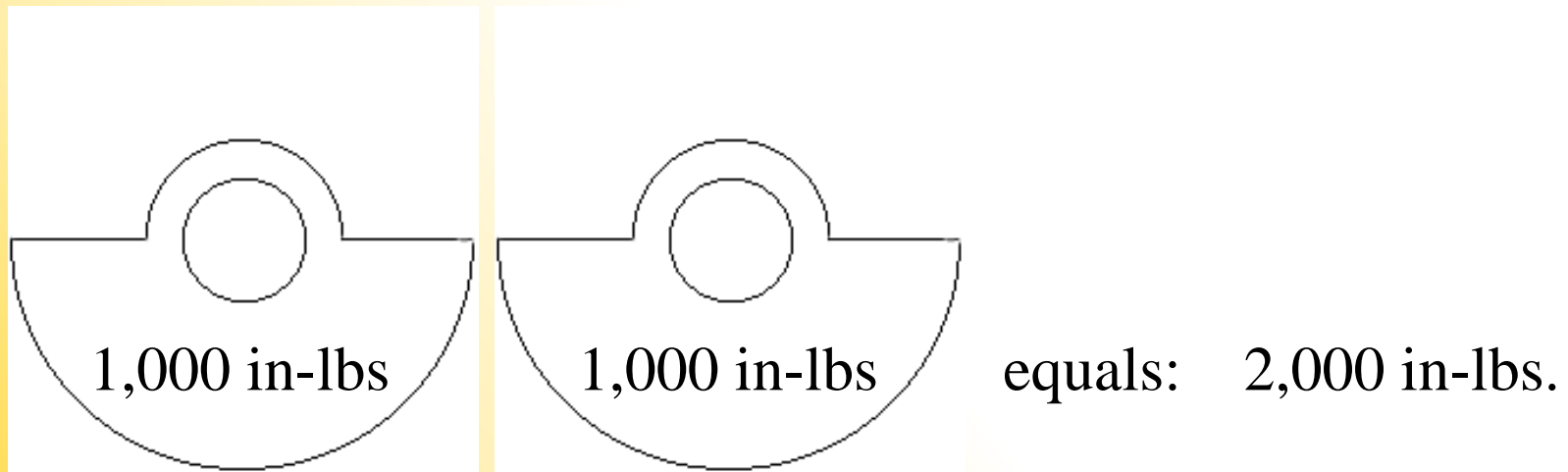

If each eccentric has 1,000 in-lbs then the vibro has a total of 2,000 in-lbs.

Some vibros Have Many Small Eccentrics to Get a Large Total Inch Pounds While Others Have Less Eccentrics That Are Bigger.

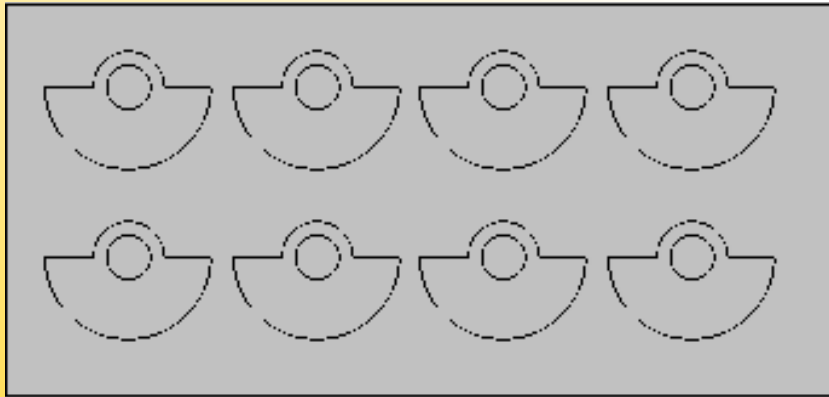

More vibrating weight
Less amplitude

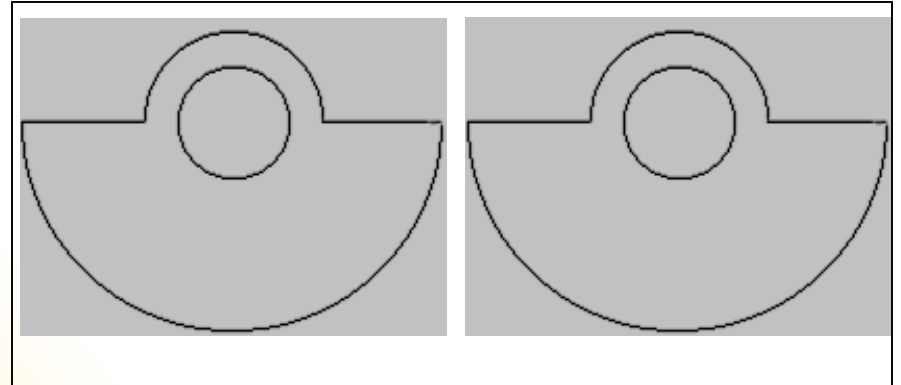

Less vibrating weight
More amplitude

Smaller Weights Means More Bearings, Shafts, Gears.

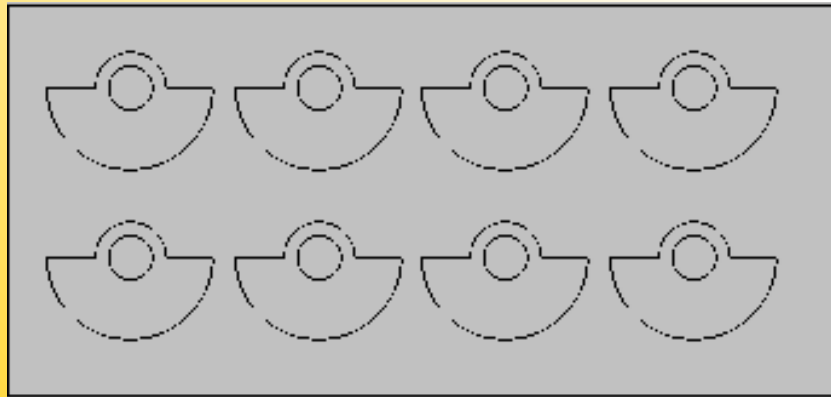

More parts

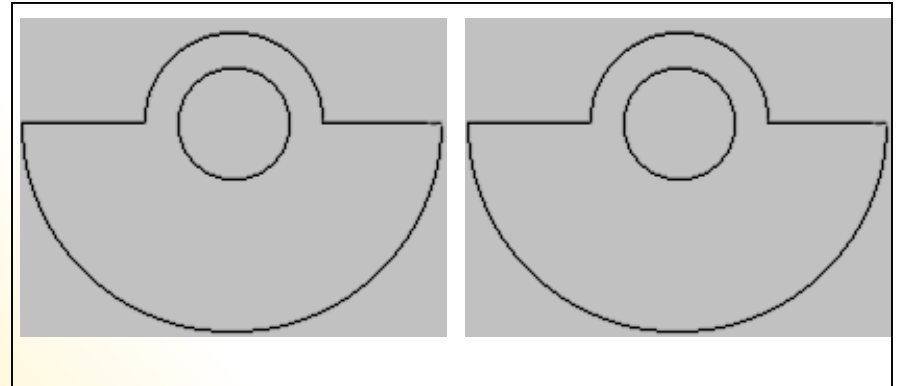

Less parts

Amplitude

$$A = \frac{2 \times Mt}{Mv}$$

Mv

Mt = Eccentric Moment in inch pounds

Mv = Total Vibrating Weight

A = Amplitude in inches

Vibrating weight: Mv

The vibrating weight is the sum of all the weights of the vibrating mass.

- B: Dynamic weight (vibrating mass)
- C: Clamping device including all plates or clamps
- D: Pile weight

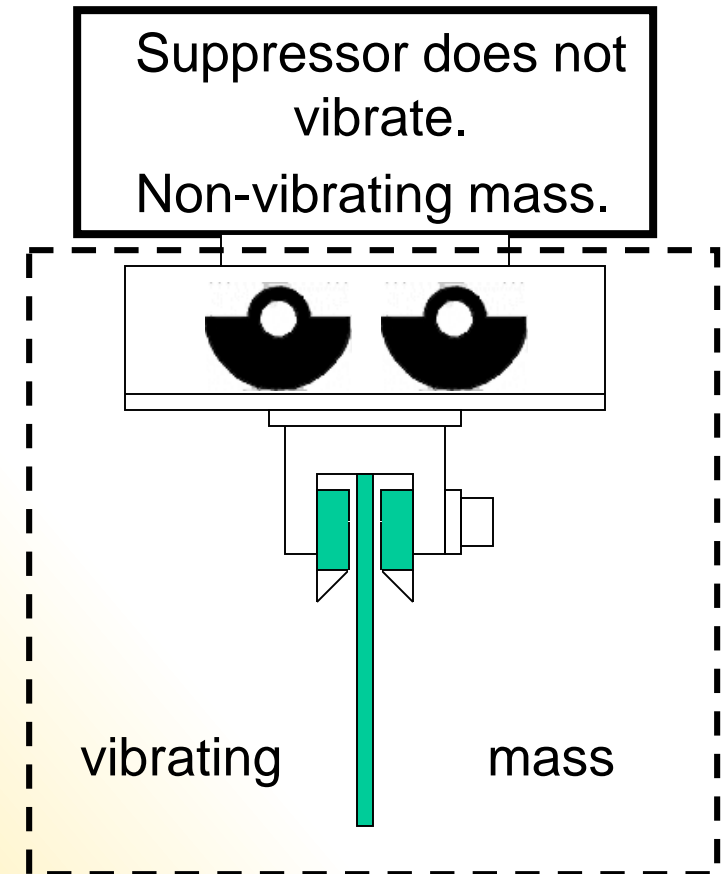

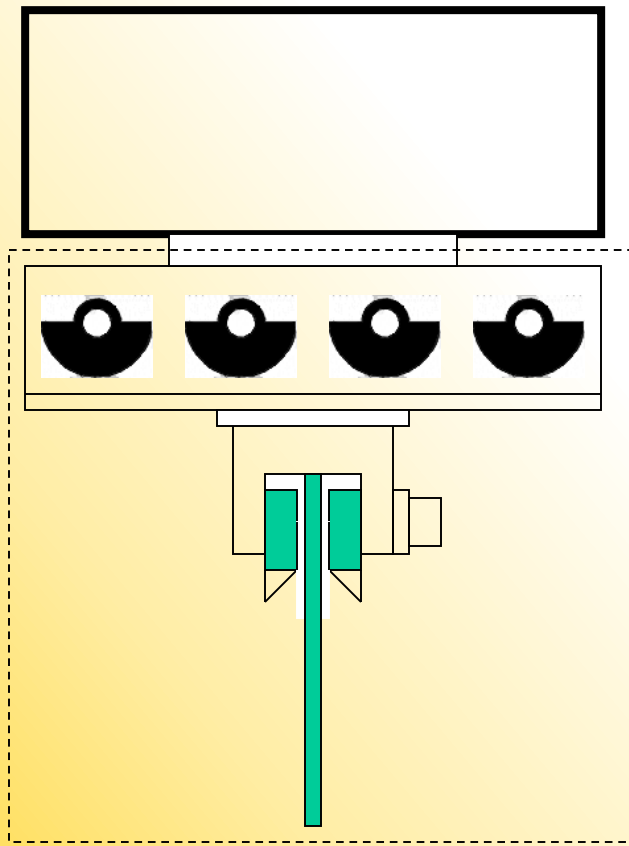

Amplitude

4000 in-lb.

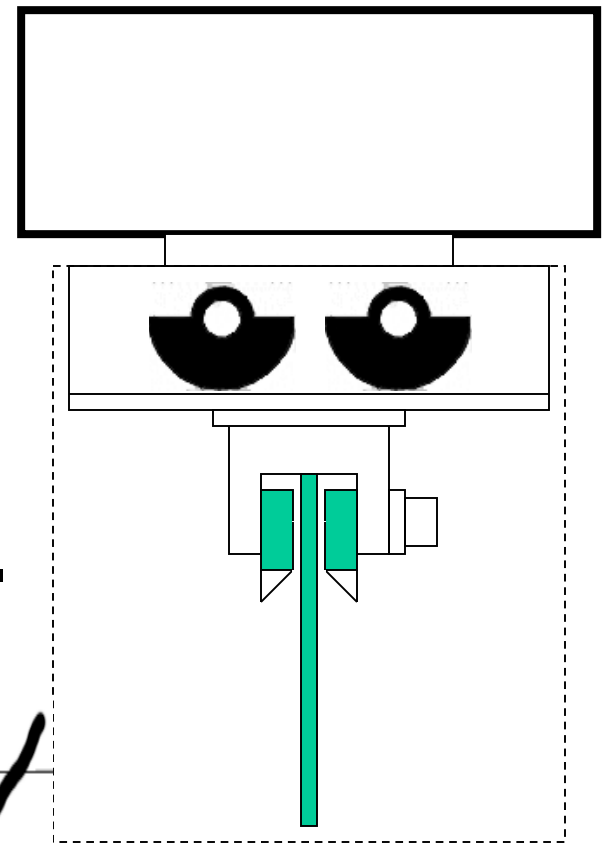

Vibrating mass: 6500 lb

Vibrating mass: 5000 lb

The hammer on the left has the same eccentric moment but less amplitude because the vibrating mass is heavier.

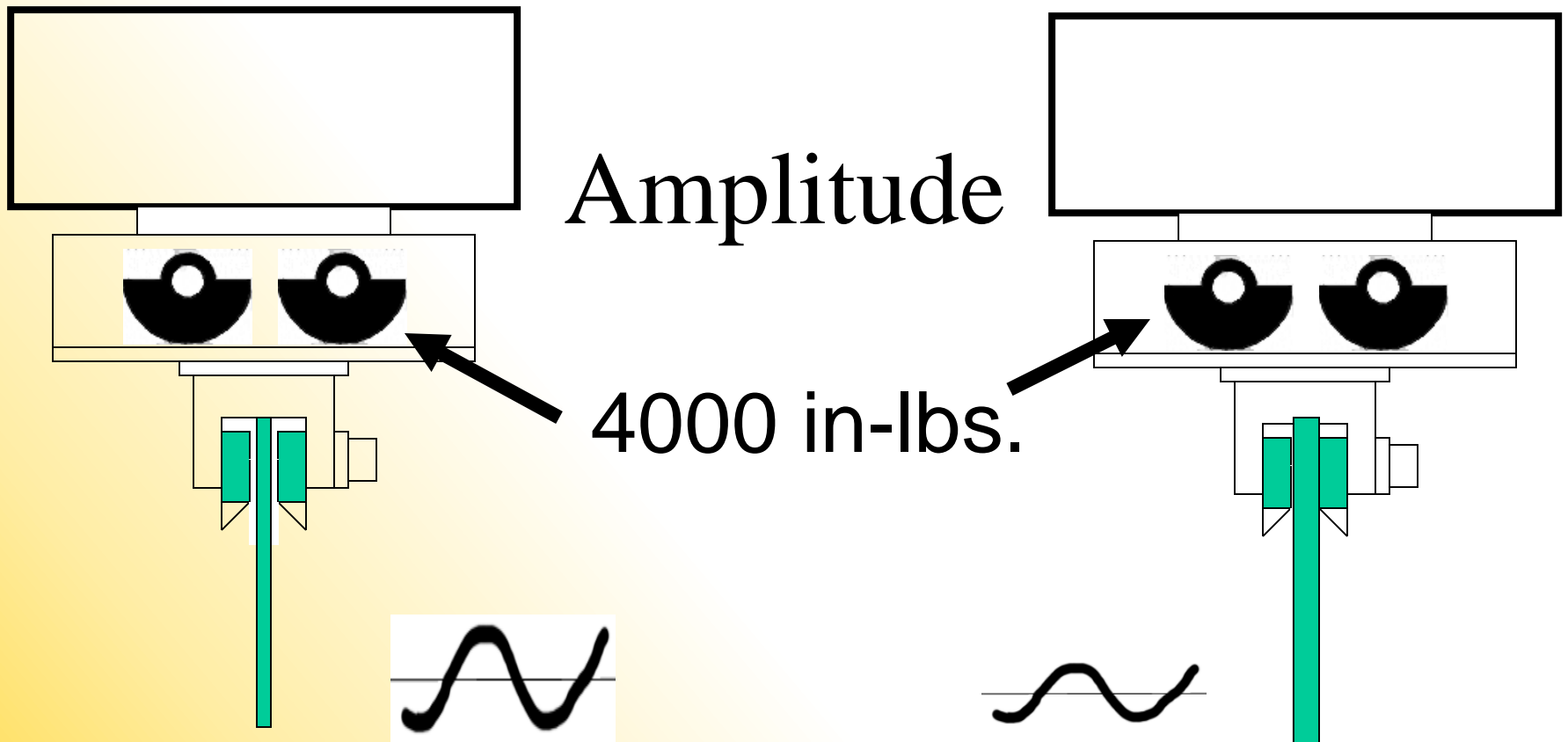

Amplitude will decrease
with increase of pile
weight. Big piles need bigger vibros
to offset loss of amplitude.

Amplitude

Amplitude will decrease with increase of:

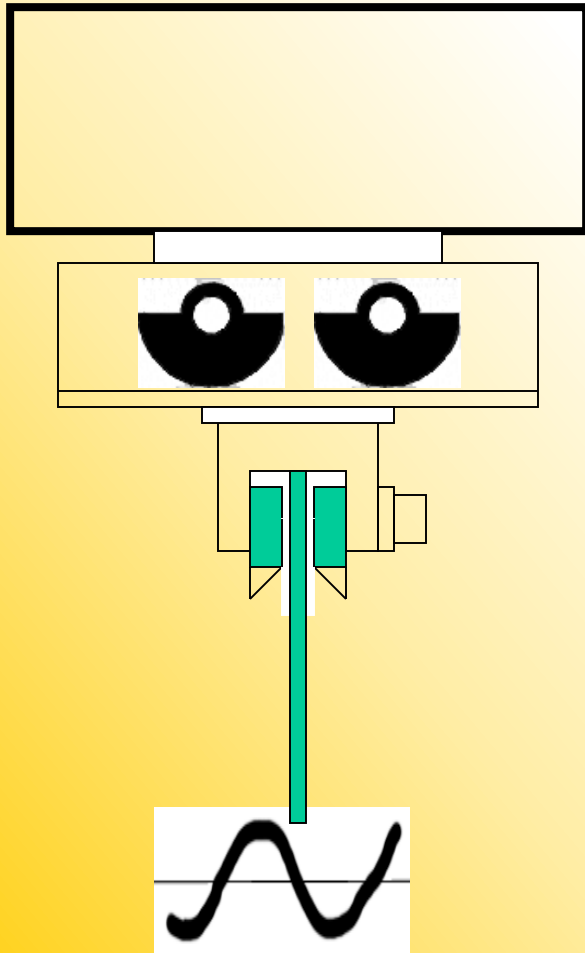

- Pile weight
- Soil resistance
- Weights, gears, shafts, hoses, motors
- Extra clamp attachments
- Anything that increases vibrating mass.

$$\text{Amplitude} = \frac{2 \times \text{EM}}{\text{VM}}$$

EM: Eccentric Moment

VM: Vibrating Mass

VPM

CPM

Frequency (Vibrations Per Minute) or (Cycles Per Minute)

Frequency is the rotational speed of the vibro eccentrics.

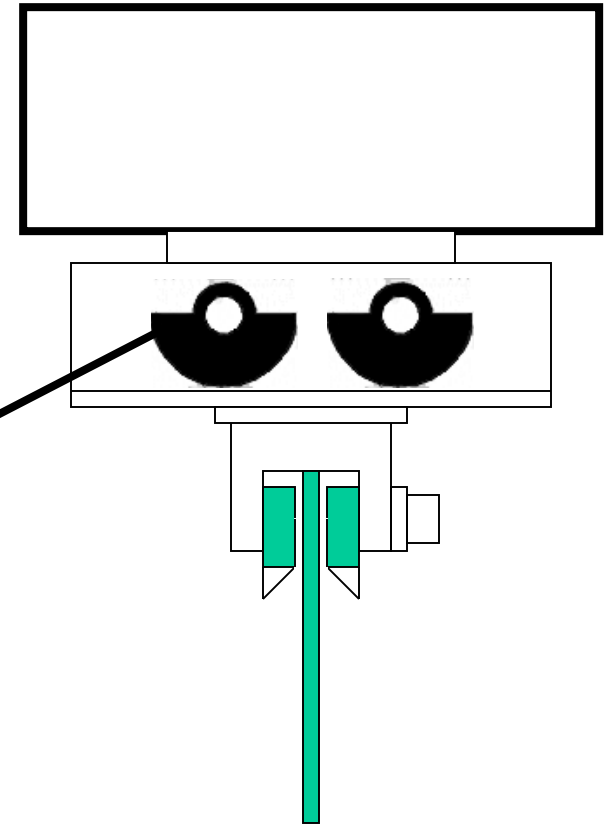
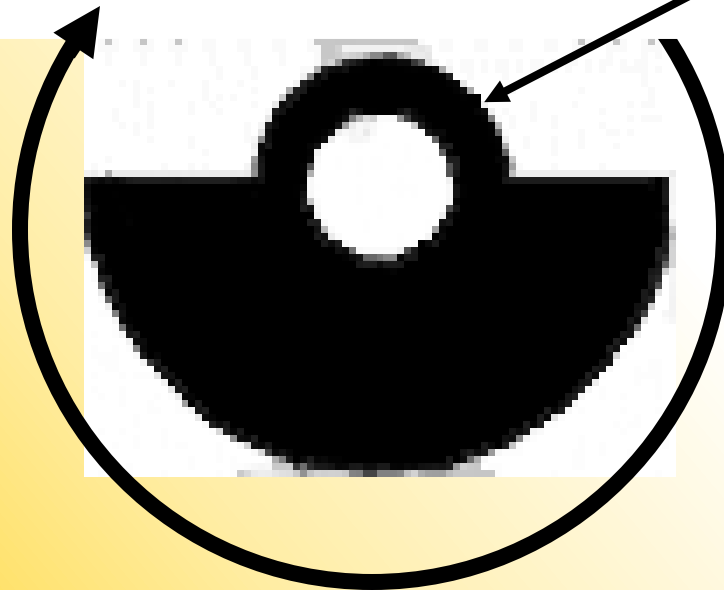

Drive Force (Dynamic Force)

(Cycles per minute)

$$\text{Drive Force} = \frac{\text{Eccentric Moment} \times 0.142 \times \text{Frequency squared}}{1,000,000}$$

Example:

Moment: 4400 in-lb.

Frequency: 1600 Cycles per minute

$$\frac{4400 \times 0.0142 \times 1600 \times 1600}{1,000,000} = 159.94 \text{ Tons}$$

Drive Force

How Frequency Matters

1100 cpm

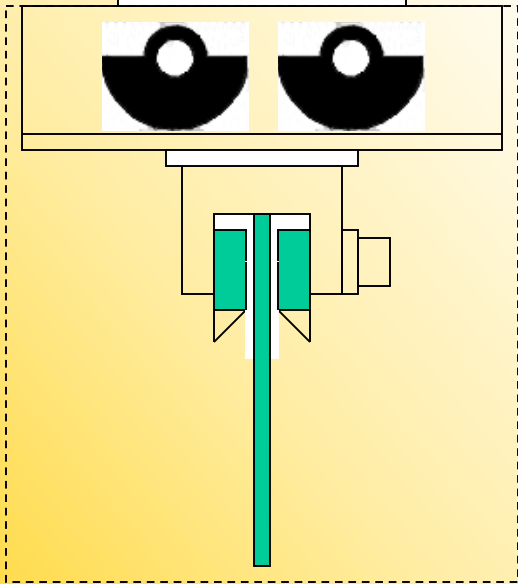

1600 cpm

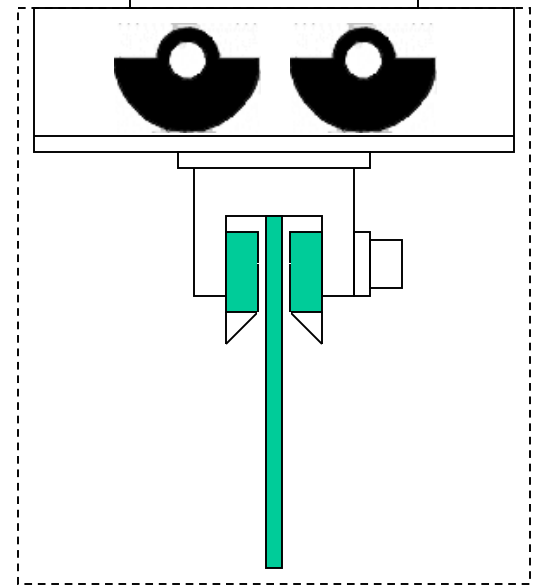

4000 in-lb.

$$\frac{4400 \times 0.0142 \times 1100 \times 1100}{1,000,000} = 75 \text{ tons}$$

$$159.94 = \frac{4400 \times 0.0142 \times 1600 \times 1600}{1,000,000}$$

Higher Frequency Dramatically Increases Drive Force Because Frequency is squared.

1100 cpm

5208 in-lbs

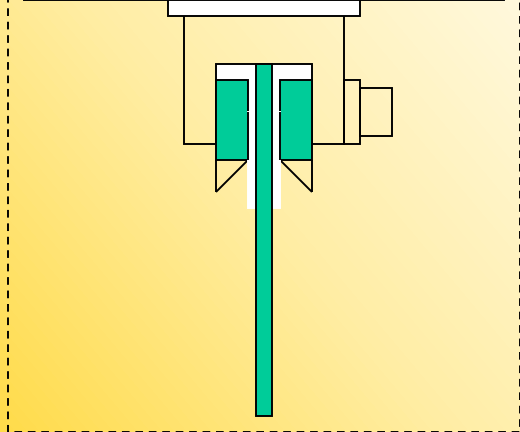

1600 cpm

4400 in-lbs

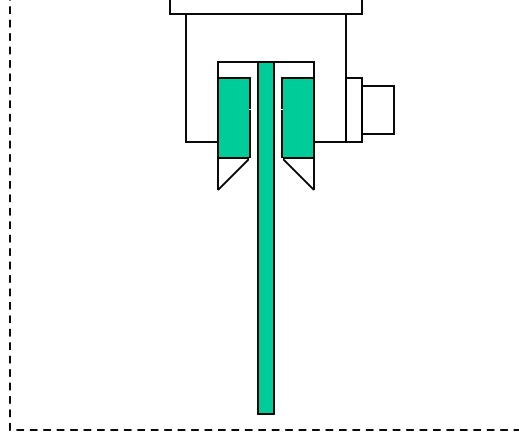

$$\frac{5208 \times 0.0142 \times 1100 \times 1100}{1,000,000} = 89 \text{ tons}$$

$$159.94 = \frac{4400 \times 0.0142 \times 1600 \times 1600}{1,000,000}$$

Vibro Jaws

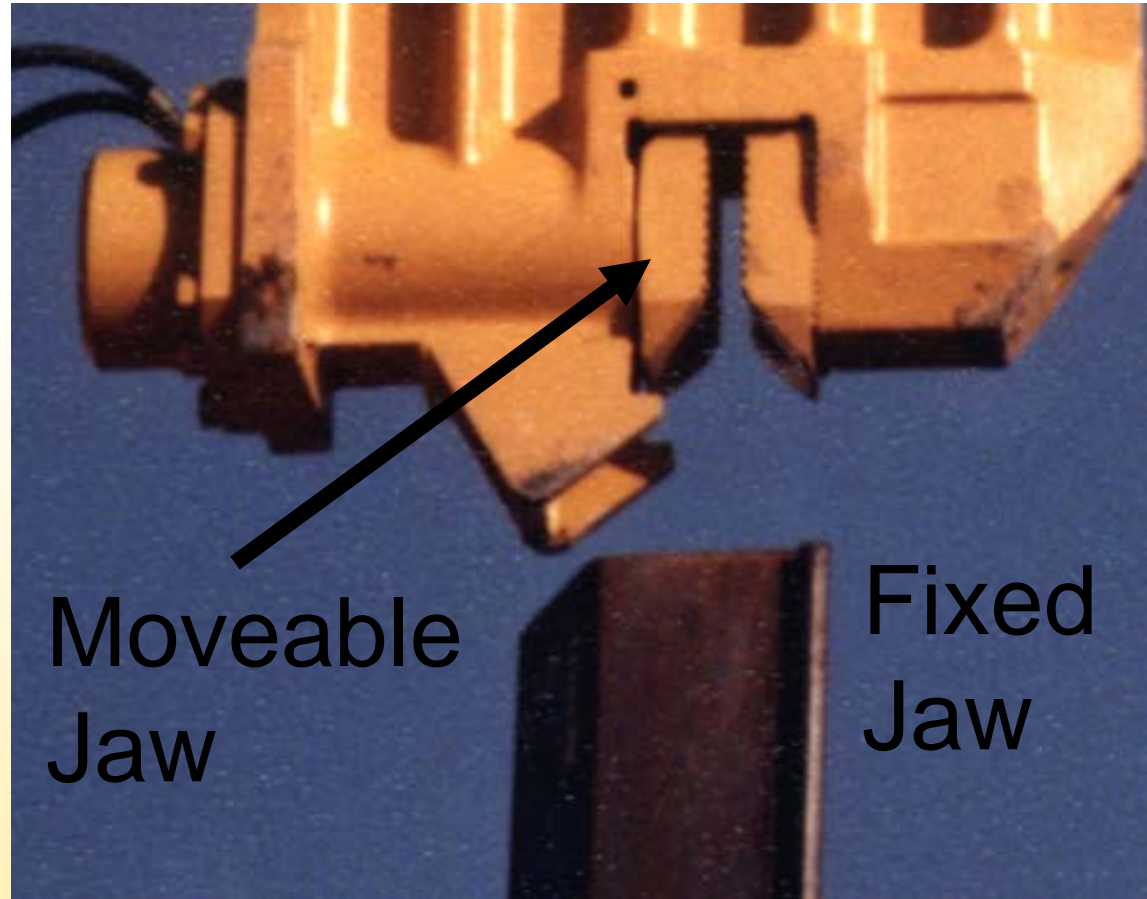
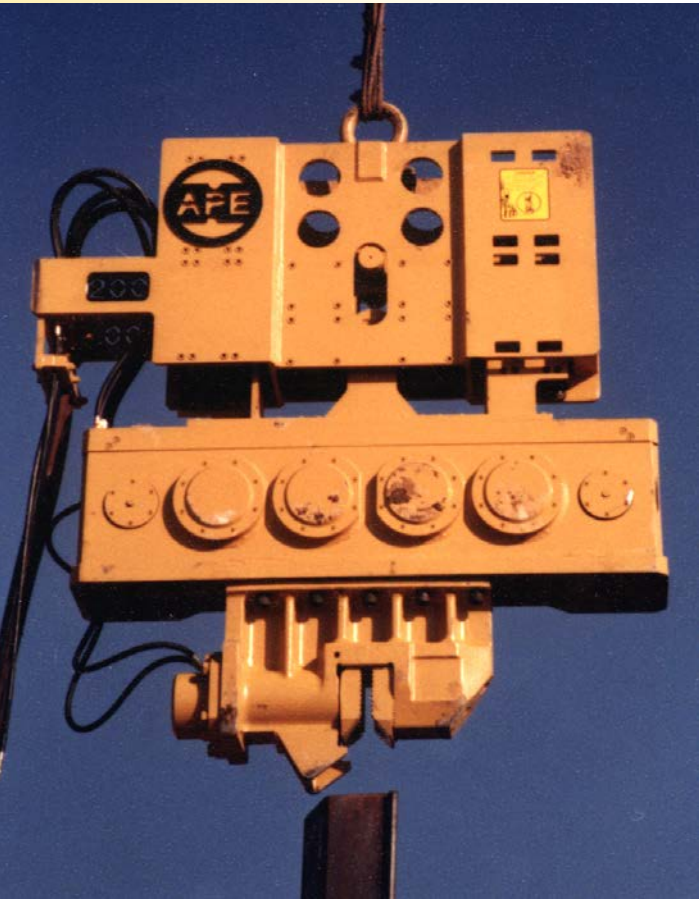

Vibro Clamps- basic Rules

- Wait for hammer to come to speed
- Clamp in center
- Clamp always in line with pile axis
- Avoid clamping on interlocks
- All of teeth in work
- Watch jaws and interlocks for heat
- Do not pull or drive vibro until speed is reached
- Do not open until vibro stops moving
- Melting interlocks means jaws are also taking a beating

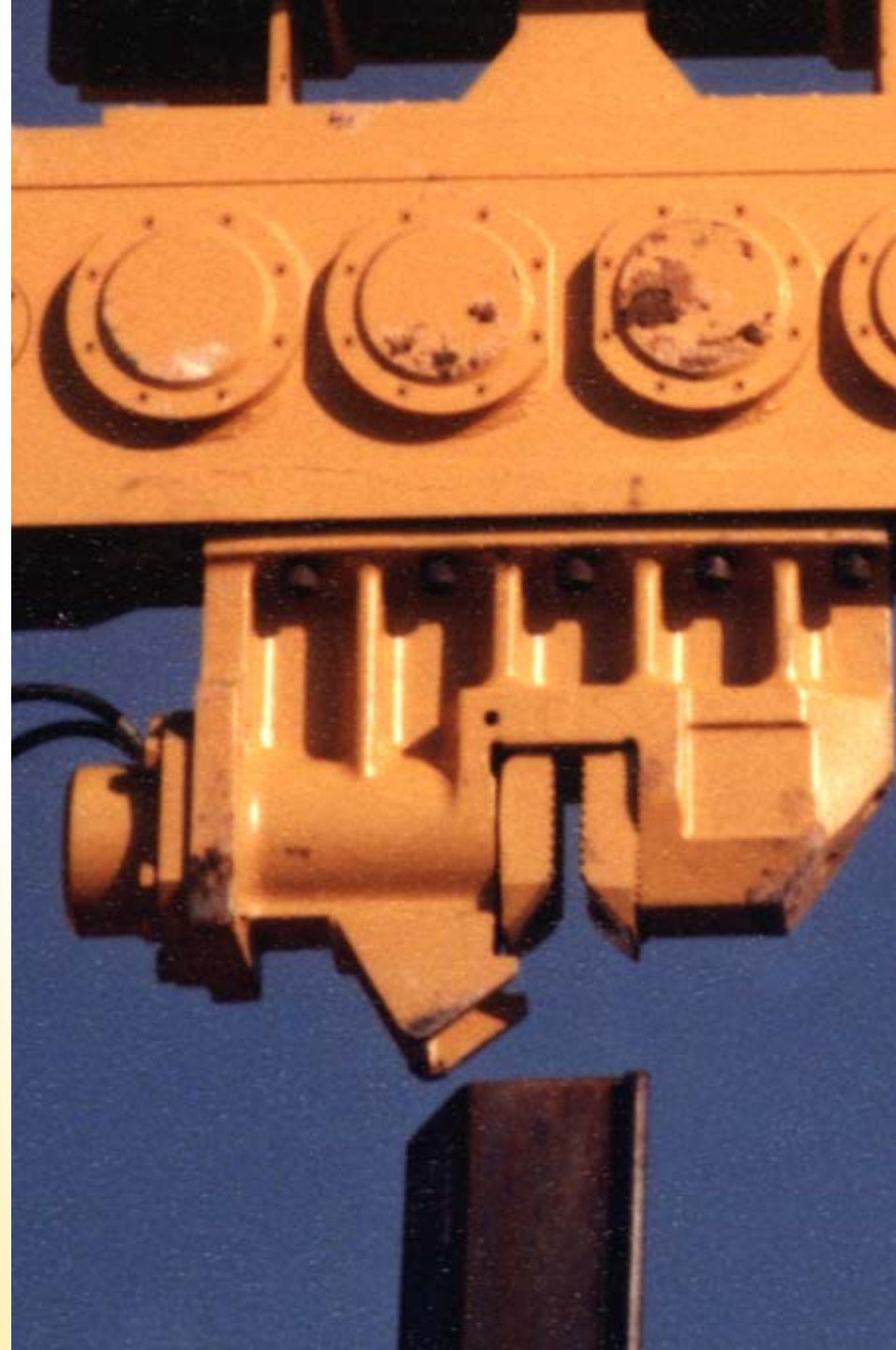

Jaws-watch the Interlocks

Do Not Crush Interlocks

Special deeper Jaws

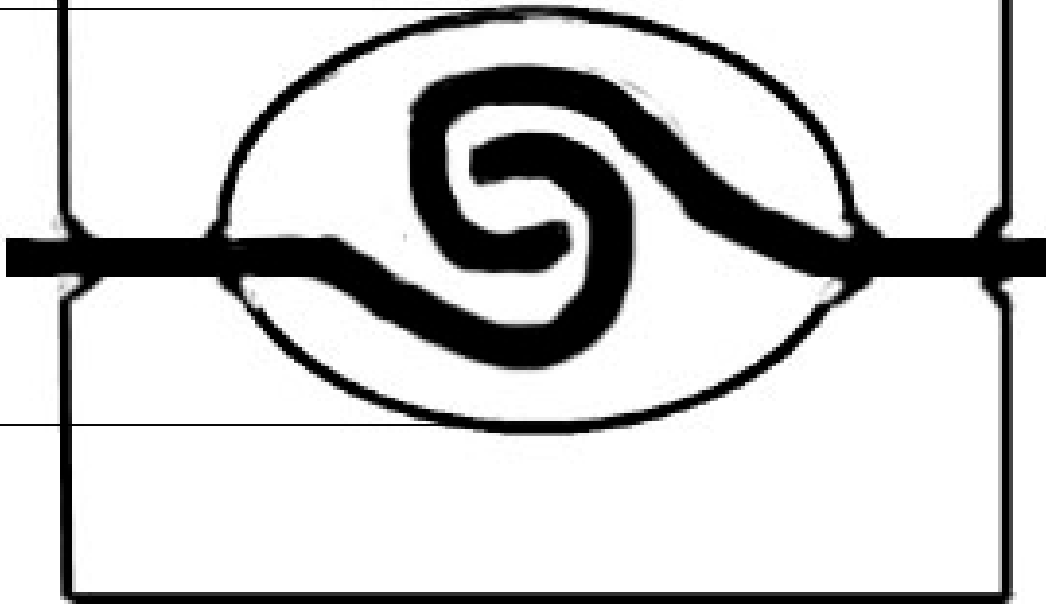

Model 400
on Sheets



Hard
Driving
Required
The
Use
Of
Super
Vibro.

Sheet piles for Air Force missile silos.

Pile Buck Tools for Driving Sheets

This tool holds leading sheet pile to lower guide.



Stab Cat

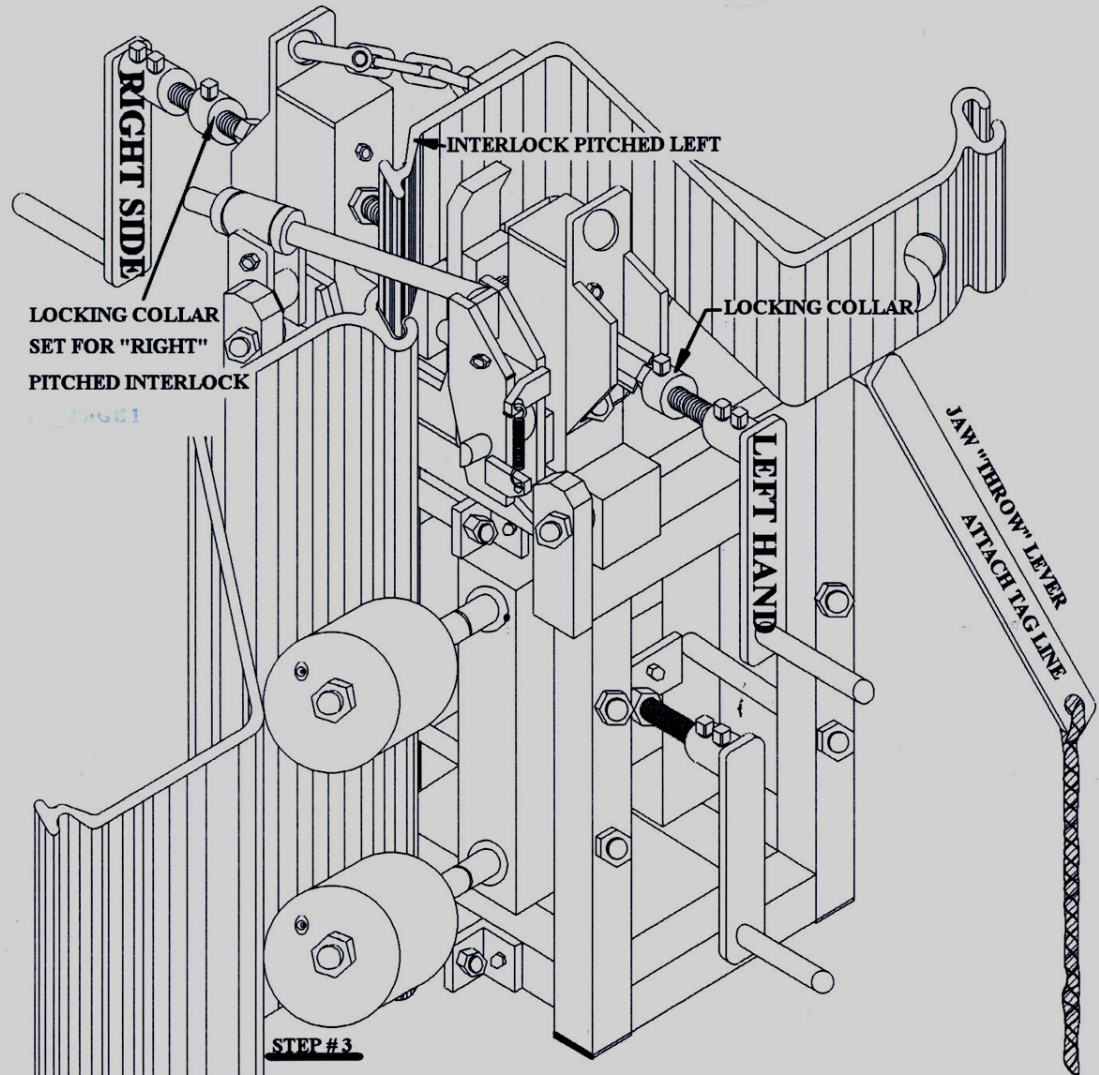

STEP #3

OPEN WHEELS AND JAWS - REMOVE BOTH COUPONS AND TURN COUPONS UP-SIDE DOWN - RE-INSTALL - TIGHTEN WHEELS AND JAWS - THE INTERLOCK WILL BE "PITCHED" LEFT - LOOSEN RIGHT HAND JAW CRANK AND TIGHTEN LEFT HAND JAW CRANK UNTIL 12" COUPON (SUSPENDED SHEET) INTERLOCK IS EXACTLY IN CENTER OF RECEIVING INTERLOCK - TIGHTEN BOTH JAW HAND CRANKS, KEEPING INTERLOCK CENTERED - LOOSEN SET SCREW IN LEFT HAND LOCKING COLLAR - SLIDE LOCKING COLLAR AGAINST JAW POST AND RE-TIGHTEN SET SCREW.

SET UP IS FOR SINGLE OR DOUBLE SHEETS